

Manual (V1.5)

PT300 series high-performance vector inverter

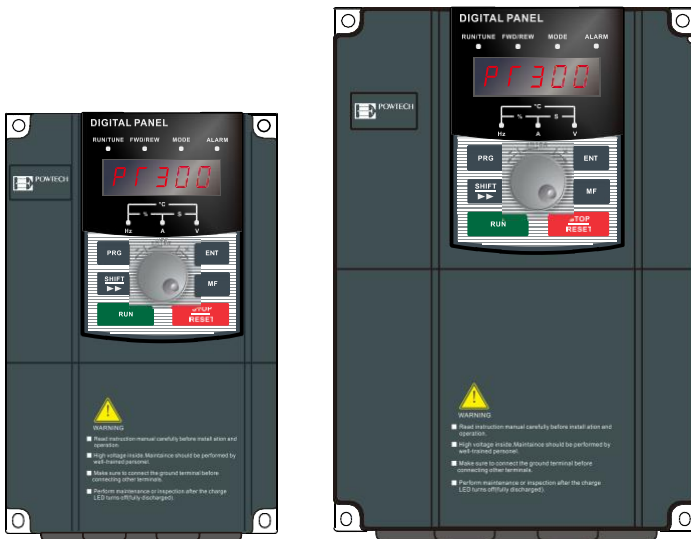

Contact us...

Email: sales@inverter.com
 Phone: +1 800-585-1519
 Website: www.inverter.com

Manual (V1.5)

high-performance vector inverter

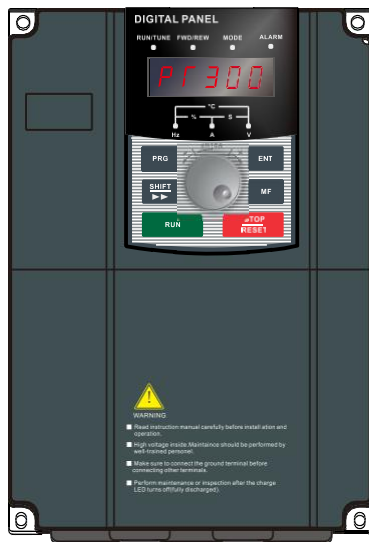
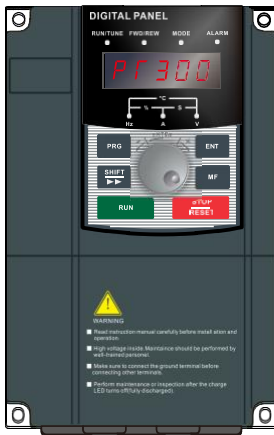

INDEX

Chapter 1 Inspections and safety precautions	1
1-1. Inspection after unpacking.....	1
1-1-1. Nameplate description.....	1
1-1-2. Model description.....	1
1-2. Safety Precautions.....	2
1-3. Precautions.....	5
1-4. Range of application.....	7
Chapter 2 Standard Specification	8
2-1. Technical Specification.....	8
2-1-1. PT300 Technical Specification (PT360 reference PT300) ..	8
2-2. Standard Specification.....	11
2-3. Dimensions.....	15
2-3-1. Outlines and installation size.....	15
2-3-2. PT300 series.....	16
2-3-3. Operation panel dimension.....	23
Chapter 3 Installation and spare circuit	25
3-1. Application environment.....	25
3-2. Installation direction and space.....	25
3-3. Wiring Diagrams.....	26
3-3-1. Wiring diagrams below 11kw(3S1/3S2/2S3).....	26
3-3-2. Wiring diagram 15kw~18.5kw(3N1).....	27
3-3-3. Wiring diagram above 22kw(3N2~2N10).....	28
3-4. Main circuit terminals.....	29
3-4-1. PT300/PT360 Main circuit terminals.....	29
3-4-2. Description of cabling terminal functions.....	31
3-5. Control circuit terminals.....	31
3-5-1. Terminal arrangement of control circuit.....	31
3-5-2. Description of control circuit terminals.....	32
3-6. Wiring Precautions.....	33
3-7. Backup Circuits.....	34
Chapter 4 Operation Panel	35
4-1. Operation panel introduction.....	35
4-2. Description of indicators.....	35

4-3. Description of keys on the operation panel.....	36
4-4. Menu style.....	37
4-4-1. Structure of level-1 menu.....	37
4-4-2. Structure of level-2 menu.....	39
4-4-3. Structure of level-3 menu.....	39
4-4-4. Common symbols of LED display.....	39
4-4-5. The LED display corresponding to the symbol.....	40
4-5. Password setting.....	40
4-6. Operation panel display and keys operation.....	41
4-6-1. Display status classification:.....	41
4-6-2. Display status and operation process SHIFT key.....	42
4-7. Operation example.....	42
4-7-1. Recovery to factory parameter.....	42
4-7-2. Set setting frequency.....	43
4-7-3. Password setting.....	43
4-7-4. Password verification.....	43
4-7-5. Password.....	44
4-8. Parameter setting mode.....	44
4-9. Pressure setting instructions.....	44
4-10. Multi-reference 0 source as encoder potentiometer setting description.....	44
4-11. Torque control mode, the encoder settings torque value instructions.....	44
Chapter 5 Commissioning.....	45
Chapter 6 Function Code Table.....	47
Group P00: Monitoring Parameters.....	48
Group P01: Basic Parameters.....	51
Group P02: Motor 1 Parameters.....	54
Group P03: Motor 1 Vector Control Parameters.....	56
Group P04: V/F Control Parameters.....	58
Group P05: Input Terminals.....	59
Group P06: Output Terminals.....	63
Group P07: Start/Stop Control.....	66
Group P08: Operation panel and display.....	67
Group P09: Auxiliary Functions.....	69

Group P10: Fault and Protection.....	72
Group P11: PID Function.....	78
Group P12: Swing Frequency, Fixed Length and Count.....	81
Group P13: Multi-Reference, Simple PLC.....	81
Group P14: Communication Parameters.....	85
Group P15: Constant pressure water supply function parameters.....	86
Group P17: Function code management.....	89
Group P18: Torque Control Parameters.....	90
Group P19: Virtual DI/DO.....	90
Group P20: Motor 2 Parameters.....	92
Group P21: Motor 3 Parameters.....	96
Group P22: Motor 4 Parameters.....	100
Group P23: Control Optimization Parameters.....	104
Group P24: AI Curve Setting.....	105
Group P26: Master-slave control parameters.....	107
Group P27: Brake function parameters.....	108
Group P30: AIAO Correction.....	108
Chapter 7 Faults and Solutions.....	110
7-1. Fault informations and solutions.....	110
7-2. Common Faults and Solutions.....	115
Chapter 8 Appendix.....	117
RS485 Extension card 300RS485.....	117
Summarize.....	117
RS485 Communication Protocol.....	117
1. Introduction.....	117
2. Specifications.....	117
I、Protocol content.....	117
II、Application mode.....	118
III、Bus structure.....	118
IV、Protocol Description.....	118
V、Communication data structure.....	118
Chapter 9 Quality Assurance.....	127

Chapter 1 Inspections and safety precautions

The PT300 inverter has been rigorously tested and inspected before leaving factory. Please confirm whether the packing is damaged during transportation and whether the nameplate model and inverter ratings are consistent with your order when purchasing .If you find any omission or damage , please contact Manufacturer or your supplier immediately.

1-1. Inspection after unpacking

- ※ Check whether an inverter , a user manual and a warranty card are contained inside it.
- ※ Check the nameplate on the side cover to ensure that it is consistent with your order.

1-1-1. Nameplate description

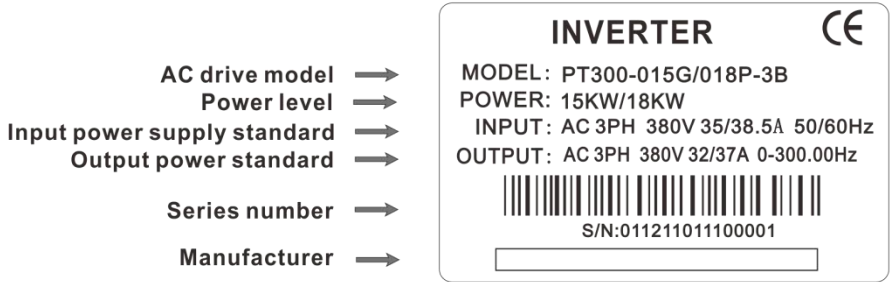

Pic 1-1 Nameplate description

1-1-2. Model description

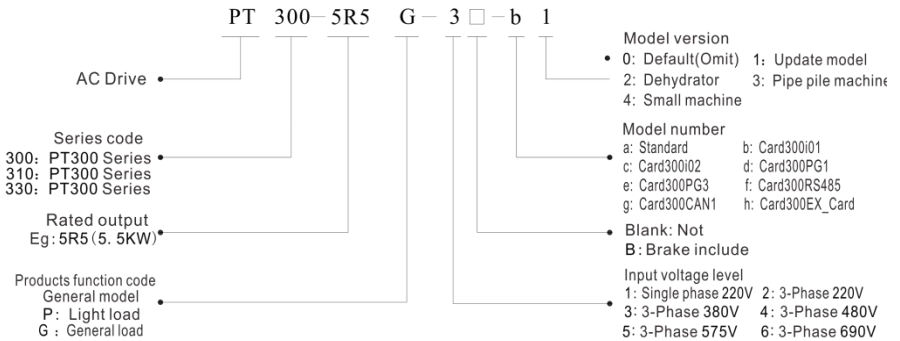

Pic 1-2 Model description

1-2.Safety Precautions

In this manual, safety precautions are classified to two kinds which are as follows:





Danger: indicates that failure to comply with the notice that will result in severe personal injury or even death;





Warning: indicates that failure to comply with the notice that will result in personal injury or property damaged.

Use stage	Safety precautions	Precautions
Before installation	 Danger	<ul style="list-style-type: none"> ●Do not install the equipment if you find water seepage, component missing or damage upon unpacking! ●Do not install the equipment if the packing list does not confirm to the product you received! ●Handle the equipment with care during transportation to prevent damage to the equipment ! ●Do not use the equipment if any component is missing or damaged .Failure to comply may result in personal injury ! ● Do not touch any component of the control system , failure to comply may result in static electricity damage !
During installation	 Danger	<ul style="list-style-type: none"> ●Install the equipment on incombustible objects such as metal, and keep it away from combustible materials. Failure to comply may result in a fire ! ●Do not loosen the fixed screws of the components , especially the screws with red mark !
	 Warning	<ul style="list-style-type: none"> ●Do not drop the wire end and screw into the inverter. Failure to comply may result in damage to inverter. ●Please install the inverter in places free of vibration and direct sunlight. ●When two or more inverters are laid in the same cabinet, arrange the installation positions properly to ensure the cooling effect.
At wiring	 Danger	<ul style="list-style-type: none"> ●It must be performed by qualified personnel under instructions described in this manual. Failure to comply may result in unexpected accidents. ●A circuit braker must be used to isolate the power supply and inverter ,

Chapter 1 Inspections and safety precautions

Use stage	Safety precautions	Precautions
At wiring		<p>failure to comply may result in a fire !</p> <ul style="list-style-type: none"> ●Please ensure that the power supply is cut-off , failure to comply may result in electric shock. ●Connect the inverter to ground by standard, failure to comply may result in electric shock. ●By no mean could connect power cables to output terminals of inverter. Pay attention to marks of wiring terminals and ensure correct wiring. Failure to comply may result in damage to inverter. ●Ensure that circuit in accordance with EMC requirement and safety standards of the region. Please refer to the manual book for advice of the wire diameter. Failure to comply may result in accidents. ●Never connect the braking resistor between DC bus terminals \oplus and \ominus . Failure to comply will result in a fire! ●Use a shielded cable for encoder , and ensure the shielding layer is reliably grounded.
Before Power-on	 Warning	<ul style="list-style-type: none"> ●Please ensure that the voltage class of power supply is consistent with the rated voltage of inverter; The input terminals (R、S、 T) and output terminals(U、 V、 W) are properly connected ;No short-circuit exists in peripheral circuit and the wiring is secured. Failure to comply may result in damage to inverter! ●Do not perform voltage resistance test on any part of the inverter because such test has been done in the factory, failure to comply may result in accidents.
	 Danger	<ul style="list-style-type: none"> ●Cover the inverter properly before power-on to prevent electric shock . ●All peripheral devices must be connected properly under instructions described in this manual .Failure to comply may result in accidents.
After Power-on	 Danger	<ul style="list-style-type: none"> ●Do not open inverter's cover after power-on. Failure to comply may result in electric shock. ●Do not touch inverter and peripheral circuit with your wet hands. Failure to comply may result in electric shock. ●Do not touch any I/O terminal of inverter. Failure to comply may result in electric shock. ●At the beginning of power-on , inverter will perform safety detection to

Chapter 1 Inspections and safety precautions

Use stage	Safety precautions	Precautions
After Power-on		<p>external circuit automatically, you can by no mean touch U、V、W of inverter connecting terminals or motor connecting terminals. Failure to comply may result in electric shock.</p> <ul style="list-style-type: none"> ●Pay attention to the rotating motor during auto turning, failure to comply may result in accidents. ●Do not change default settings of inverter , failure to comply may result in damage to inverter.
During operation	 Danger	<ul style="list-style-type: none"> ●Do not touch fan or discharge resistor to check the temperature. Failure to comply may result in personal injury. ●Signal detection must be performed only by qualified personnel during operation. Failure to comply may result in personal injury or damage to inverter.
	 Warning	<ul style="list-style-type: none"> ●Avoid objects falling into inverter when the inverter is running, failure to comply may result in damage to inverter. ●Do not start/stop the inverter by control the contactor ON/OFF.Failure to comply may result in damage to inverter.
During maintenance	 Danger	<ul style="list-style-type: none"> ●Do not repair or maintain the inverter at power-on, failure to comply may result in electric shock. ●Repair or maintain the inverter when DC bus voltage is lower than 36V, and it is based on 2min after power-off. Or else that the residual voltage of the capacity will result in personal injury. ●Repair or maintain of the inverter only can be performed by qualified personnel. Failure to comply may result in personal injury or damage to inverter. ●Set and check the parameters after inverter is replaced , and all pluggable components must be plugged or removed only after power-off.

Chapter 1 Inspections and safety precautions

1-3.Precautions

No.	Type	Precautions
1	Motor insulation check	Perform the motor insulation test when the motor is used for the first time or when it is reused after being stored for a long time or in a regular check-up, in order to prevent the poor insulation of motor windings from damaging the inverter. The motor must be disconnected from the inverter during the insulation test. A 500V mege-ohm is recommended for the test. The insulation resistance must not less than 5 MΩ.
2	Thermal protection of the motor	If the rated capacity of the motor does not match that of the inverter, especially when inverter's rated capacity is greater than motor's, adjust the protection parameters of inverter or install a thermal relay in the motor circuit for protection.
3	Running at over 50/60HZ	The inverter provides the output frequency of 0Hz~500.00Hz. If the inverter is required to run at over 50/60HZ, consider the capacity of the machine.
4	Vibration of mechanical device	The inverter may encounter mechanical resonance point at some output frequencies, which can be avoided by setting the skip frequency.
5	Motor heat and noise	The output of the inverter is pulse width modulation wave(PWM) which contains certain harmonic frequencies, therefore , the motor temperature、noise、and vibration are slightly greater than those when the inverter runs at power frequency.
6	Voltage-sensitive device or capacitor on output side of the inverter	Do not install capacitor for improving power factor or lighting protection voltage-sensitive resistor because the output of the inverter is PWM wave. Otherwise, the inverter will suffer transient over current or even damaged.
7	Contactor at I/O terminal of the inverter	When a contactor is installed between input side of the inverter and the power supply, the inverter must not be started or stopped by switching contactor ON/OFF. If the inverter has to be operated by the contactor, ensure that the time interval between switching is at least one hour. Frequent charge and discharge will shorten the service life of the capacitor inside the inverter. When a contactor is installed between output side of the inverter and the motor, do not turn off the contactor when inverter is active, otherwise, the module inside the inverter may be damaged.

Chapter 1 Inspections and safety precautions

No.	Type	Precautions
8	Using out of the rated voltage range	The PT300 series inverter must not be used outside the allowable voltage range, otherwise, the components inside the inverter may be damaged. If required, use a corresponding set-up or set-down device.
9	3-phase input changes into 2-phase input	Do not change 3-phase input into 2-phase input of PT300 inverter. Otherwise, a fault will be result or the inverter may be damaged.
10	Lightning Surge suppressor	The inverter has built-in overcurrent protection device which can auto-protect the inverter from lightning. The user should install some protective devices before the inverter in the places where the lightning is frequent.
11	Altitude and de-rating	In places where the altitude is above 1000m and the cooling effect reduces due to the thin air, it is necessary to de-rate the inverter. Please contact the Manufacturer for technical support.
12	Some special usage	If wiring that is not described in this manual such as common DC bus applied, please contact the Manufacturer for technical support.
13	Precautions when inverter scraps	The electrolytic capacitor on the main circuits and PCB may explode when they are burnt. Poisonous gas is generated when plastic parts are burnt. Treat them as ordinary industrial waste.
14	Adaptable Motor	<p>1)The standard adaptable motor is four-pole squirrel-cage asynchronous induction motor. For other types of motor, select the proper inverter according to the rated motor current.</p> <p>2)The cooling fan and rotor shaft of non-variable-frequency motor are coaxial, the cooling effect reduces when the rotational speed declines, therefore, it should add a powerful fan or replace it to a variable-frequency motor in places where the motor overheats easily.</p> <p>3)The standard parameters of adaptable motor have been configured inside the inverter, it is necessary to perform motor auto-turning or modify the default values based on the actual conditions. Otherwise, the running and protection performance will be affected.</p> <p>4)The inverter may alarm or even be damaged when short-circuit exists on cables or inside the motor. Therefore, perform insulation short-circuit test when the motor and cables are newly installed or during routine maintenance. Ensure that the inverter is disconnected from the tested parts during the test.</p>

Chapter 1 Inspections and safety precautions

No.	Type	Precautions
15	Others	<p>1) Never connect the power supply to the output terminals U、V、W of the inverter.</p> <p>2) The operation panel must be fixed and locked well before power-on, so as to avoid the personal injury due to the bad capacitors of the internal components.</p> <p>3) Do not perform the wiring and checking after power-on.</p> <p>4) Do not touch the internal circuit boards and components after power-on, in order to avoid the electric-shock hazard.</p> <p>5) Do not touch the internal circuit boards and other parts within 5min after operation panel display goes off since power-off, and must use the instrument to confirm the capacitor has been discharged before perform the inside work , failure to comply will result in electric-shock.</p> <p>6) Static electricity of the body can severely damage the MOSFET, Please do not touch the internal components such as PCB and IGBT parts when anti-static measures are not taken, or it will cause fault.</p> <p>7) The ground terminal (E or \perp) of inverter needs to be grounded correctly and relative in accordance with National Electrical Safety regulations and other relevant standards when in use .Please do not shut off the power of the inverter directly to stop the motor until the motor has stopped its operation.</p> <p>8) The accessories such as input filter should be added with the CE standard.</p>

1-4.Range of application

- ※ The PT300 inverter is generally applied to 3-phase AC asynchronous motor.
- ※ The AC drive can only be used in the case that the company approved, unapproved use may cause fire 、 electric-shock 、 explosions and other events.
- ※ If the inverter used in the equipment that may cause personal injury or death (such as : Lifting equipment for transporting personnel, aerospace systems, safety equipment, etc), it must be carefully treated. Please contact Manufacturer for technical consult in this case.

Only trained personnel are allowed to operate the inverter, please read the safety、 installation、 operation and maintenance section of the manual before using. The safe operation of the inverter depends on proper transport 、 installation 、 operation and maintenance !

Chapter 2 Standard Specification

2-1. Technical Specification

2-1-1. PT300 Technical Specification (PT360 reference PT300)

Model	Input voltage	Rated output Power(KW)	Rated input current(A)	Rated output current(A)	Adaptable motor
PT300-0R4G-1B	Single phase 220V ±15%	0.4	5.4	2.1	0.4
PT300-0R7G-1B		0.75	8.2	4.0	0.75
PT300-1R5G-1B		1.5	14.0	7.0	1.5
PT300-2R2G-1B		2.2	23.0	9.6	2.2
PT300-004G-1B		3.7	34.0	17.0	3.7
PT300-0R4G-2B	3-phase 220V ±15%	0.4	3.4	2.1	0.4
PT300-0R7G-2B		0.75	5.0	3.8	0.75
PT300-1R5G-2B		1.5	9.2	7.0	1.5
PT300-2R2G-2B		2.2	10.5	9.0	2.2
PT300-004G-2B		3.7	14.6	13	3.7
PT300-5R5G-2B		5.5	26.0	25	5.5
PT300-7R5G-2B		7.5	35.0	32	7.5
PT300-011G-2		11.0	46.5	45	11.0
PT300-015G-2		15.0	62.0	60	15.0
PT300-018G-2		18.5	76.0	75	18.5
PT300-022G-2		22.0	92.0	90	22.0
PT300-030G-2		30.0	115.0	110	30.0
PT300-037G-2		37.0	157.0	152	37.0
PT300-045G-2		45.0	180.0	176.0	45.0
PT300-055G-2		55.0	214.0	210.0	55.0
PT300-075G-2	75.0	307.0	304.0	75.0	
PT300-0R7G/1R5P-3B	3-phase 380V ±15	0.75/1.5	3.4/5.0	2.1/3.8	0.75/1.5
PT300-1R5G/2R2P-3B		1.5/2.2	5.0/5.8	3.8/5.1	1.5/2.2
PT300-2R2G/003P-3B		2.2/3.0	5.8/7.9	5.1/7.0	2.2/3.0
PT300-003G/004P-3B		3.0/3.7	7.0/9.0	7.0/9.0	3.0/3.7
PT300-004G-3B		3.7	10.5	9.0	3.7
PT300-5R5P-3B		5.5	14.6	13	5.5
PT300-5R5G/7R5P-3B		5.5/7.5	14.6/20.5	13/17	5.5/7.5
PT300-7R5G-3B		7.5	20.5	17	7.5
PT300-011P-3B		11	26	25	11
PT300-011G/015P-3B		11/15	26/35	25/32	11/15
PT300-015G/018P-3B		15/18.5	35/38.5	32/37	15/18.5

Chapter 2 Standard Specification

Model	Input voltage	Rated output Power(KW)	Rated input current(A)	Rated output current(A)	Adaptable motor
PT300-018G/022P-3	3-phase 380V ±15%	18.5/22	38.5/46.5	37/45	18.5/22
PT300-022G/030P-3		22/30	46.5/62	45/60	22/30
PT300-030G/037P-3		30/37	62/76	60/75	30/37
PT300-037G/045P-3		37/45	76/92	75/90	37/45
PT300-045G/055P-3		45/55	92/113	90/110	45/55
PT300-055G/075P-3		55/75	113/157	110/152	55/75
PT300-075G/090P-3		75/90	157/180	152/176	75/90
PT300-090G/110P-3		90/110	180/214	176/210	90/110
PT300-110G/132P-3		110/132	214/256	210/253	110/132
PT300-132G/160P-3		132/160	256/307	253/304	132/160
PT300-160G/185P-3		160/185	307/344	304/340	160/185
PT300-185G/200P-3		185/200	344/385	340/380	185/200
PT300-200G/220P-3		200/220	385/430	380/426	200/220
PT300-220G/250P-3		220./250	430/468	426/465	220/250
PT300-250G/280P-3		250/280	468/525	465/520	250/280
PT300-280G/315P-3		280/315	525/590	520/585	280/315
PT300-315G/355P-3		315/355	590/665	585/650	315/350
PT300-355G/400P-3		355/400	665/785	650/725	350/400
PT300-400G/450P-3		400/450	785/833	725/820	400/450
PT300-450G-3		450	883	820	450
PT300-500G-3		500	926	860	500
PT300-560G-3	560	1023	950	560	
PT300-630G-3	630	1184	1100	630	
PT300-0R7G-4B	3-phase 480V ±15%	0.75	3.4	2.1	0.75
PT300-1R5G-4B		1.5	5.0	3.8	1.5
PT300-2R2G-4B		2.2	5.8	5.1	2.2
PT300-003G-4B		3.0	7.9	7.0	3.0
PT300-004G-4B		3.7	10.5	9.0	3.7
PT300-5R5G-4B		5.5	14.6	13	5.5
PT300-7R5G-4B		7.5	20.5	17.0	7.5
PT300-011G-4B		11.0	26.0	25.0	11.0
PT300-015G-4B		15.0	35.0	32.0	15.0
PT300-018G-4		18.5	38.5	37.0	18.5
PT300-022G-4		22.0	46.5	45.0	22.0
PT300-030G-4		30.0	62.0	60.0	30.0
PT300-037G-4		37.0	76.0	75.0	37.0

Chapter 2 Standard Specification

Model	Input voltage	Rated output Power(KW)	Rated input current(A)	Rated output current(A)	Adaptable motor
PT300-045G-4	3-phase 480V ±15%	45.0	92.0	90.0	45.0
PT300-055G-4		55.0	113.0	110.0	55.0
PT300-075G-4		75.0	157.0	152.0	75.0
PT300-090G-4		90.0	180.0	176.0	90.0
PT300-110G-4		110.0	214.0	210.0	110.0
PT300-132G-4		132.0	256.0	253.0	132.0
PT300-160G-4		160.0	307.0	304.0	160.0
PT300-185G-4		185.0	344.0	340.0	185.0
PT300-200G-4		200.0	385.0	380.0	200.0
PT300-220G-4		220.0	430.0	426.0	220.0
PT300-250G-4		250.0	468.0	465.0	250.0
PT300-280G-4		280.0	525.0	520.0	280.0
PT300-315G-4		315.0	590.0	585.0	315.0
PT300-355G-4		355.0	665.0	650.0	350.0
PT300-400G-4		400.0	785.0	725.0	400.0
PT300-450G-4		450.0	883.0	820.0	450.0
PT300-500G-4		500.0	926.0	860.0	500.0
PT300-560G-4		560.0	1023.0	950.0	560.0
PT300-630G-4	630.0	1184.0	1100.0	630.0	
PT300-055G-6	3-phase 690V ±15%	55.0	70.0	62.0	55.0
PT300-075G-6		75.0	90.0	85.0	75.0
PT300-090G-6		90.0	105.0	102.0	90.0
PT300-110G-6		110.0	130.0	125.0	110.0
PT300-132G-6		132.0	170.0	150.0	132.0
PT300-160G-6		160.0	200.0	175.0	160.0
PT300-200G-6		200.0	235.0	215.0	200.0
PT300-220G-6		220.0	247.0	245.0	220.0
PT300-250G-6		250.0	265.0	260.0	250.0
PT300-280G-6		280.0	305.0	299.0	280.0
PT300-315G-6		315.0	350.0	330.0	315.0
PT300-355G-6		355.0	382.0	390.0	350.0
PT300-400G-6		400.0	435.0	410.0	400.0
PT300-450G-6		450.0	490.0	465.0	450.0
PT300-500G-6		500.0	595.0	550.0	450.0
PT300-560G-6	560.0	605.0	590.0	450.0	

Chapter 2 Standard Specification

2-2. Standard Specification

Items		Specifications
Basic function	Maximum Frequency	V/F control: 0-500Hz(0.01Hz resolution) 0-3000Hz(0.1Hz resolution) Vector control: 0-500Hz
	Starting torque	0.25Hz/150% (VF、SVC) ; 0Hz/180% (FVC)
	Speed stability accuracy	Sensorless vector control(SVC): $\leq \pm 0.5\%$ (rated synchronous speed) PG vector control(FVC): $\leq \pm 0.02\%$ (rated synchronous speed)
	Torque control accuracy	$\pm 5\%$ (FVC)
	Overload capacity	G type: Rated current 150%—1min, Rated current 180%—3s P type: Rated current 120%—1min, Rated current 150%—3s
	Torque boost	Automatic boost; Customized boost 0.1%~30.0%
	V/F curve mode	Three types: Linear, User-defined V/F curve, N-power(1.2 power, 1.4 power, 1.6 power, 1.8 power, 2 power)
	V/F separation	2 types: complete separation, half separation;
	Acc/Dec curves	Straight-line Acceleration/Deceleration or S-curve Acceleration/Deceleration model Four groups of Acceleration/Deceleration time with the range of: 0-6500.0s
	DC braking	DC braking frequency : 0.0Hz~maximum frequency Braking time : 0.0~36.0s Braking action current value : 0.0%~100.0%
	JOG control	JOG frequency range: 0.00Hz~50.00s; JOG Acc/Dec time : 0.0s~6500.0s
	Simple PLC, multi-speed control	It implements up to 16 speeds via PLC function or combination of DI terminal states.
	Built-in PID	It realizes process-controlled close loop control system easily
	Auto voltage regulation(AVR)	It can keep constant output voltage automatically when the mains voltage changes.
Overcurrent / overvoltage stall	The voltage and current are limited automatically during the running process so as to avoid frequency tripping due to	

Chapter 2 Standard Specification

Items		Specifications
	control	overvoltage / overcurrent.
	Rapid current limit function	Minimize the overcurrent fault, protect the normal operation of the inverter
	Torque limit and control	"Excavator" characteristics, it can limit the torque automatically and prevent frequent overcurrent tripping during running process; Torque control can be implemented in the CLVC mode.
	Slip compensation	50~100%, Auto slip compensation
	Rotation speed startup tracking mode	The inverter can track the motor rotation speed when startup.
	inverter protection	Overvoltage protection, undervoltage protection, overcurrent protection, overload protection, overheat protection, overcurrent stall protection, overvoltage stall protection, phase loss protection, External equipment protection , communication fault , PID feedback signal abnormal , PG fault
	inverter fan control	The fan start temperature can be set
Individualized function	DC bus shared function	It can realize multiple inverters share one DC bus function.
	Virtual IO	5 groups of virtual DI/DO can realize the simple PLC logic function
	Multi-motor switchover	4 motors can be switched over via 4 groups of motor parameters
	Multiple encoder types	It sports various encoder types such as differential encoder open-collector encoder, UVW encoder and rotary encoder.
	Motor overheat protection	Select IO extension card 1, analog signal input AI3 can adopts the input signal of motor temperature sensor PT100, PT1000.
	 Key	Programmable key : Select FWD/REV or JOG running function
	Textile swing control	Multiple triangle wave frequency control function
	Pulse by pulse	Built-in pulse by pulse current limit algorithm, reduce the

Chapter 2 Standard Specification

Items		Specifications
	current limit function	possibility of inverter failure , and enhance the anti-disturbance ability .
	Timing function	Timing control function: time setting range is 0-6500.0Min
	Instantaneous stop constantly	When instantaneous power supply failure, reducing offset voltage by load feedback energy, To maintain and continue the inverter running in a short time
	Standard operation panel extend cable	The customer can use the standard net cable to extend the operation panel cable.
	Advanced master-computer monitoring software	It supports the operation of inverter parameters and Virtual oscilloscope function
	High performance	Control of asynchronous and synchronous motor are implemented through the high-performance current vector control technology, and have done a special software compensation algorithm aiming at low frequency torque and torque stability of the industry.
RUN	Running command source	Three sources : Operation panel、Control terminals and serial communication ports . You can perform switchover between these sources in various ways.
	Frequency source	There are 12 frequency sources in total , such as: Digital setting , analog voltage setting , analog current setting, pulse setting , simple PLC setting , multi-reference setting, PID control setting , serial communication port setting and these frequency sources can be switched over in various ways .
	Auxiliary frequency source	There are 12 auxiliary frequency sources in total, it can implement fine turning of auxiliary frequency and frequency synthesis .
	Input terminal	Standard: 5 digital input terminals, one of which supports up to 100KHz high-speed pulse input

Items		Specifications
		<p>2 analog input terminals, one of which only supports 0-10V voltage input or 4-20mA current input.</p> <p>Expanding capacity:</p> <p>3 digital input terminals</p> <p>1 analog input terminals, which supports 0-10V voltage input or 4-20mA current input and also supports PT100/PT1000</p>
	Output terminal	<p>Standard:</p> <p>1 high-speed pulse output terminal(open-collector) that supports 0-100KHz square wave signal output .</p> <p>1 digital output terminal</p> <p>1 relay output terminal</p> <p>1 analog output terminal that supports 0~20mA current output or 0~10V voltage output .</p> <p>Expanding capacity :</p> <p>1 digital output terminal</p> <p>1 relay output terminal</p> <p>1 analog output terminal that supports 0~20mA current output or 0~10V voltage output .</p>
Display and panel operation	IGBT temperature display	It displays the current temperature of IGBT.
	Parameter protection function	Protect the inverter parameters by setting administrator password and decoding
	LED display	Display parameters
	OLED display	Optional part , Chinese/English operation
	Parameter copy	Use the parameter copy key to realize the fast copy of parameters (only for OLED)
	Key locking and function selection	It can lock the keys partially or completely and define the function range of some keys so as to prevent mis-function
	Optional parts	300EX_CARD , 300IO1 extension card , 300IO2 extension card , 300PG1 extension card, 300PG2 extension card, 300RS485 extension card and so on .
Communication	RS485/RS232	It can communicate to the master computer via choosing completely isolated RS485/RS232 communication module

Chapter 2 Standard Specification

Items		Specifications
Environment	Environment temperature	-10℃~40℃ (De-rated if the ambient temperature is 40℃~50℃)
	Storage temperature	-20℃~65℃
	Environment Humidity	Less than 90 % R.H
	Altitude . Vibration	Lower than 1000 m, Less than 5.9m/s ² (=0.6g)
	Application location	In room, without sunlight or corrosive, explosive gases and water vapor, no dust, flammable gas, oil mist, steam, drop or salt, etc.
	Altitude	Lower than 1000 m
	Pollution degree	2
	Comply with EMC standard	IEC61800-3: 2005
	Cooling method	Forced cooling or natural cooling

2-3. Dimensions

2-3-1.Outlines and installation size

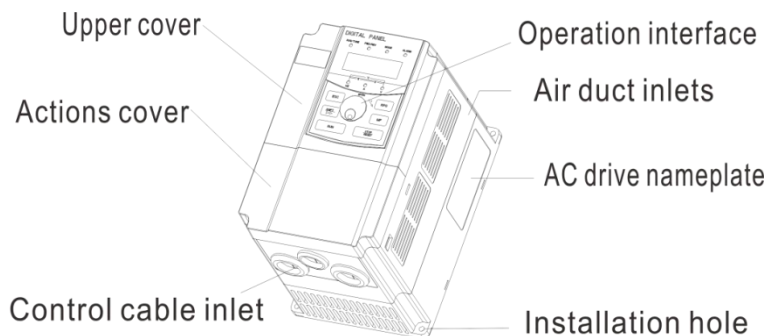

Pic 2-1 Outlines and installation size

2-3-2. PT300 series

1.3S1~2S3

1) 3S1

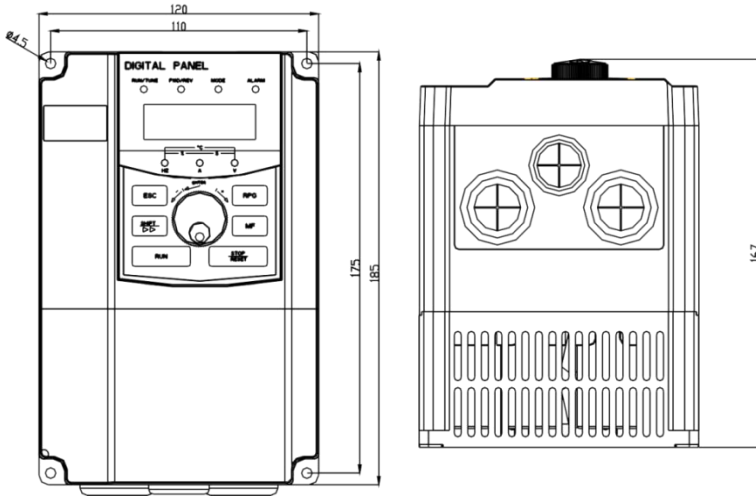

Pic 2-2 3S1 dimension

Power source	Type	Power (KW)
Single phase 220V	G	0.4~2.2
3-phase 220V	G	0.4~2.2
3-phase 380V	G	0.75~4

Chapter 2 Standard Specification

2)3S2

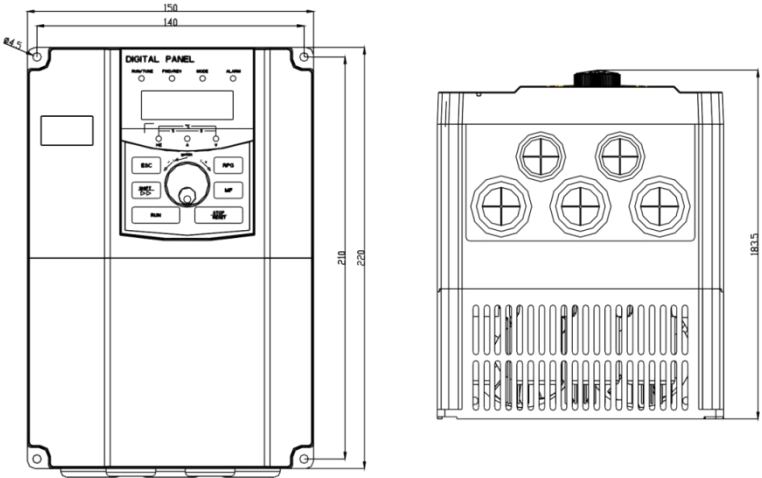

Pic 2-3 3S2 dimension

Power source	Type	Power (KW)
Single phase 220V	G	4
3-phase 220V	G	4
3-phase 380V	G	5.5~7.5

3) 2S3

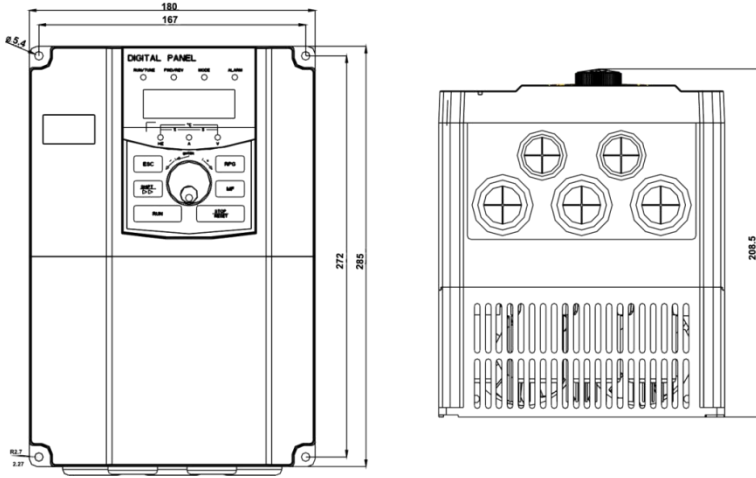

Pic 2-4 2S3 dimension

Power source	Type	Power (KW)
3-phase 2200V	G	5.5-7.5kw
3-phase 380V	P	11kw
3-phase 380V	G	11kw

Chapter 2 Standard Specification

2.3N1~3N6

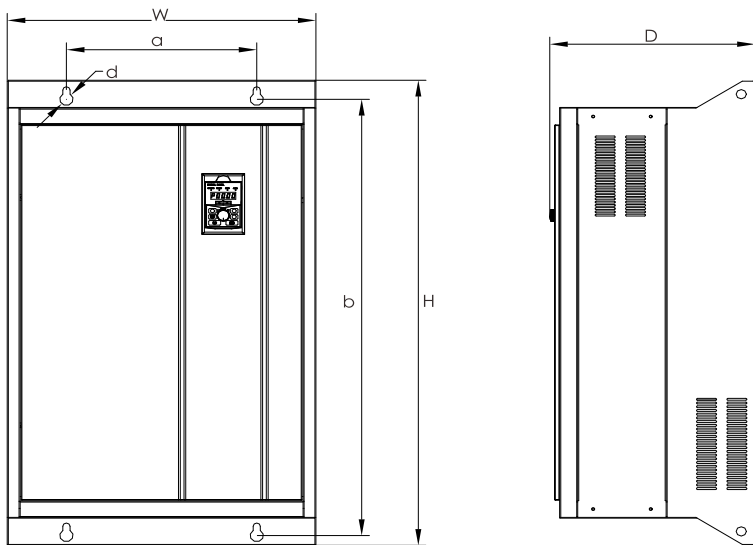

Pic 2-5 3N1-3N6 dimension

1)3N1

Type	Power (KW)	Frame NO.	Dimensions			Installation size		
			H	W	D	a	b	d
G	15~18.5	3N1	345	203	230	150	325	Ø9
P	18.5~22							

2)3N2

Type	Power (KW)	Frame NO.	Dimensions			Installation size		
			H	W	D	a	b	d
G	22~37	3N2	430	263	255	170	407	Ø9
P	30~45							

3)3N3

Type	Power (KW)	Frame NO.	Dimensions			Installation size		
			H	W	D	a	b	d
G	45~55	3N3	490	310	274	190	468	Ø10
P	55~75							

4)3N4

Type	Power (KW)	Frame NO.	Dimensions			Installation size		
			H	W	D	a	b	d
G	75~90	3N4	565	346	308	240	537	Ø9.5
P	90~110							

5)3N5

Type	Power (KW)	Frame NO.	Dimensions			Installation size		
			H	W	D	a	b	d
G	110~132	3N5	610	376	313	240	582	Ø9.5
P	132~160							

6)3N6

Type	Power (KW)	Frame NO.	Dimensions			Installation size		
			H	W	D	a	b	d
G	160~250	3N6	786	500	353	300	748	Ø14
P	185~280							

7)3N8(Wall-mounted)

Type	Power (KW)	Frame NO.	Dimensions			Installation size		
			H	W	D	a	b	d
G	280~400	3N8	1160	650	400	370	1100	Ø14
P	315~450							

3.3N6~3N8(Cabinet with base)

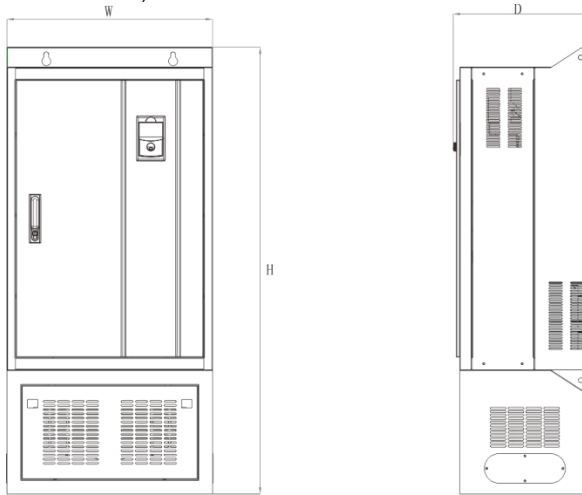

Pic 2-6 3N6-3N8 Cabinet size with base

1)3N6(Cabinet with base)

Type	Power (KW)	Frame NO.	Dimensions			Installation size		
			H	W	D	a	b	d
G	160~250	3N6	1100	500	353	/	/	/
P	185~280							

2)3N8 (Cabinet with base)

Type	Power (KW)	Frame NO.	Dimensions			Installation size		
			H	W	D	a	b	d
G	280~400	3N8	1460	650	400	/	/	/
P	315~450							

4. 2N9~2N10

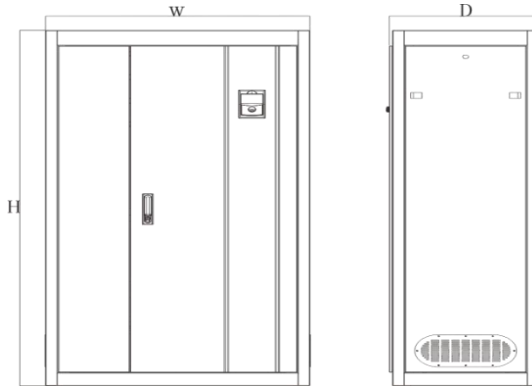

Pic 2-7 2N9 Cabinet dimension

1) 2N9(Cabinet)

Type	Power (KW)	Frame NO.	Dimensions			Installation size		
			H	W	D	a	b	d
G	450~560	2N9	1650	830	480	/	/	/
P	500~630							

2) 2N10(Cabinet)

Type	Power (KW)	Frame NO.	Dimensions			Installation size		
			H	W	D	a	b	d
G	630~700	2N10	1850	1080	580	/	/	/
P	700~800							

Chapter 2 Standard Specification

2-3-3. Operation panel dimension

JP6C300 dimension:

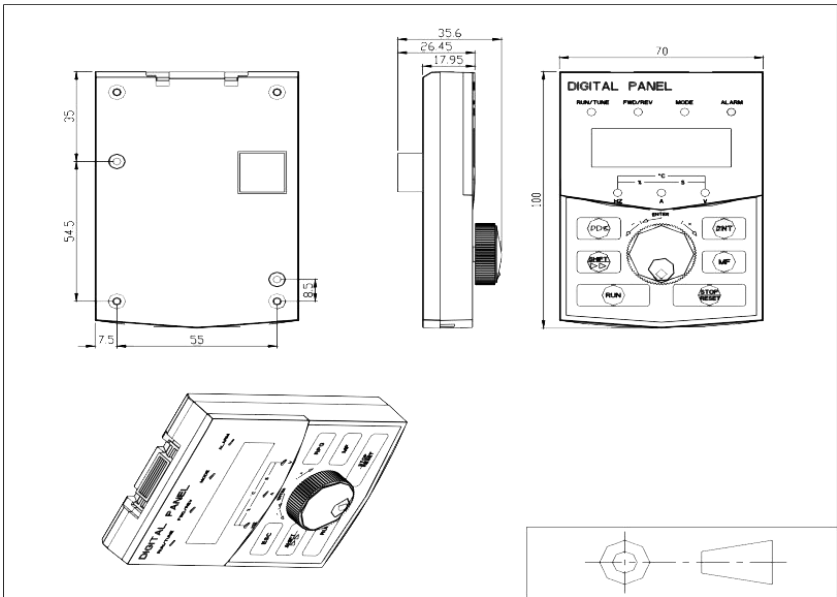

Pic 2-8 JP6C300 dimension

JP6E300 dimension :

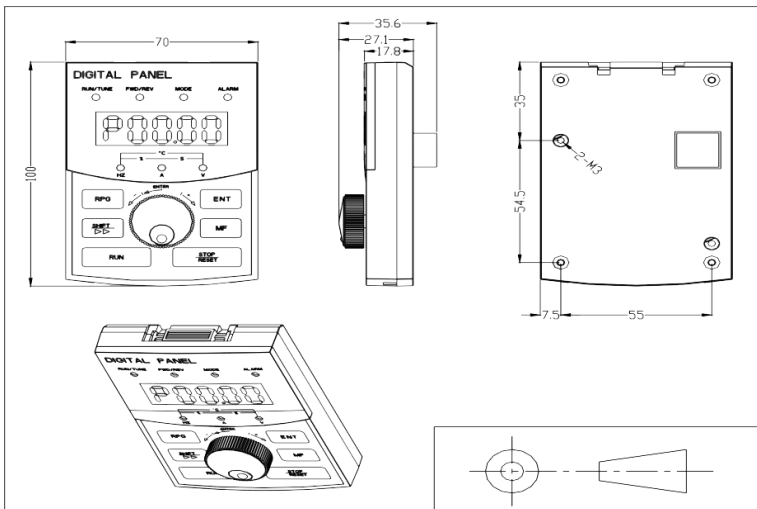

Pic 2-9 JP6E300 dimension

JP6D200 Keyboard housing dimension:

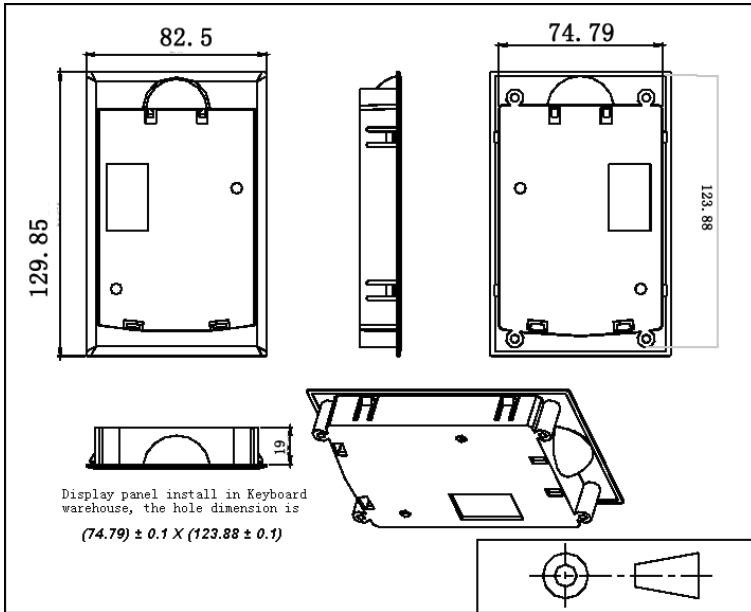

Pic 2-10 JP6D200 Dimension

Chapter 3 Installation and spare circuit

Chapter 3 Installation and spare circuit

3-1. Application environment

- (1) Ambient temperature $-10^{\circ}\text{C} \sim 40^{\circ}\text{C}$.
- (2) Avoid electromagnetic interference, keep away from the interference sources.
- (3) Avoid water, steam, dust, lint and the invasion of the metal powder.
- (4) Avoid oil, salt and corrosive gas invasion.
- (5) Avoid vibration.
- (6) Avoid high temperature, high humidity and no rain water spray, humidity is less than 90% RH (No condensation).
- (7) It is prohibited to use in dangerous environment such as flammable and combustible, explosive gas, liquid or solid.

3-2. Installation direction and space

AC drive shall be installed in the ventilated places of indoor, and takes the wall-mounted, which should keep enough space with the surrounding items or walls. As follows:

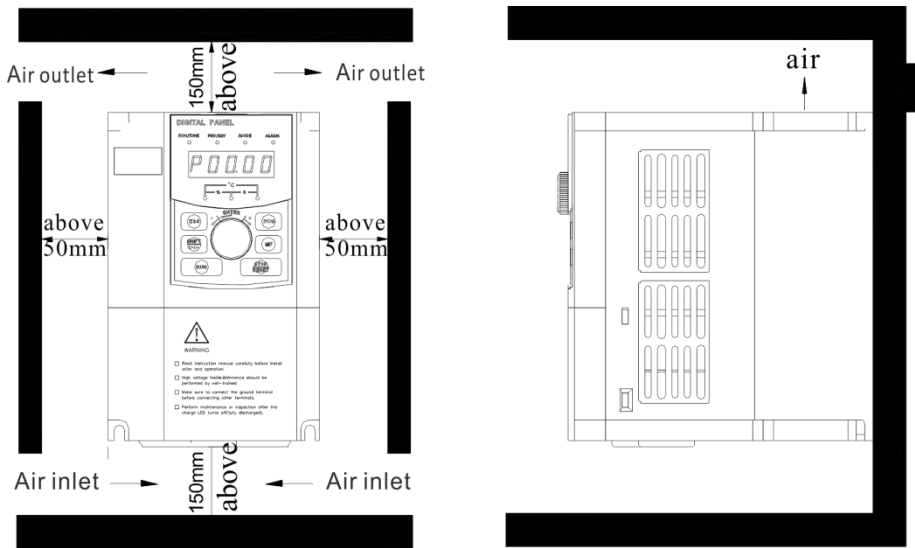

Pic 3-1 Installation direction and space

3-3.Wiring Diagrams

The inverter wiring includes main circuit and controlled circuit two parts. The user must be connecting wires right according to wiring diagram below.

3-3-1. Wiring diagrams below 11kw(3S1/3S2/2S3)

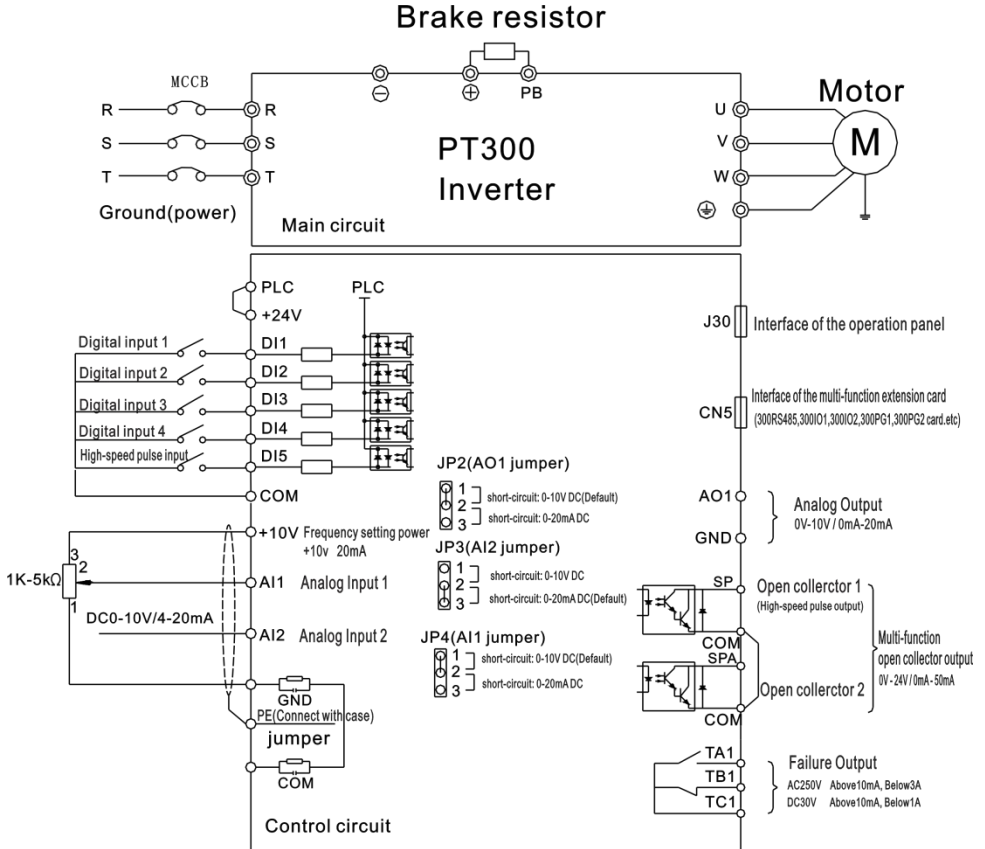

Pic 3-2 Wiring Diagrams below 11kw(3S1/3S2/2S3)

3-3-2. Wiring diagram 15kw~18.5kw(3N1)

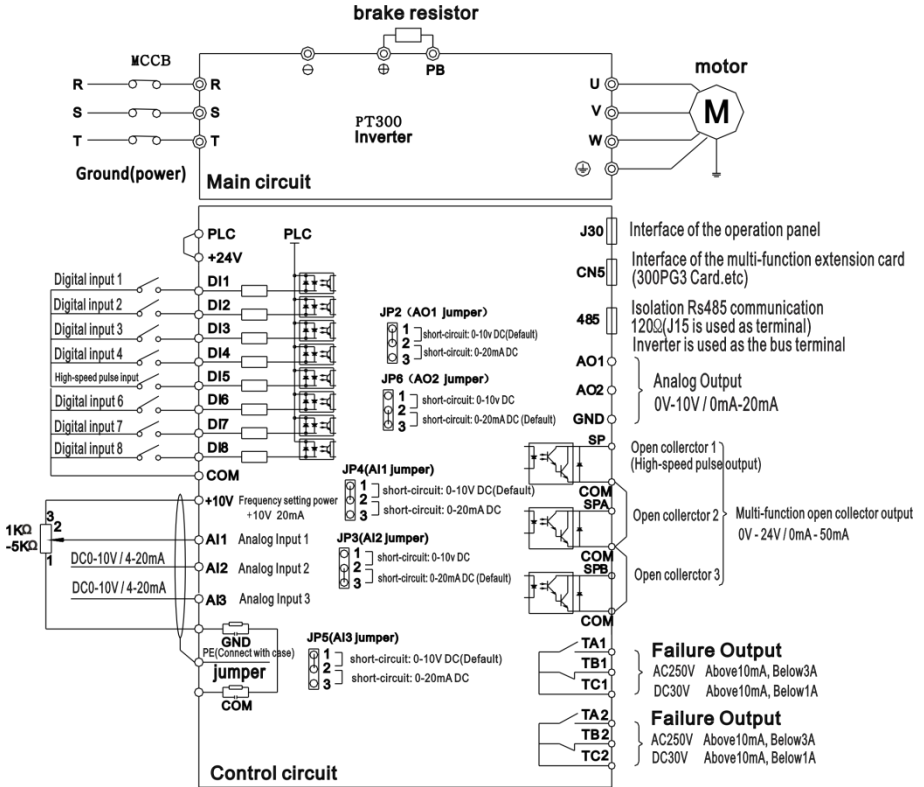

Pic3-3 11-15KW wiring diagram(3N1)

3-3-3. Wiring diagram above 22kw(3N2~3N8/2N9~2N10)

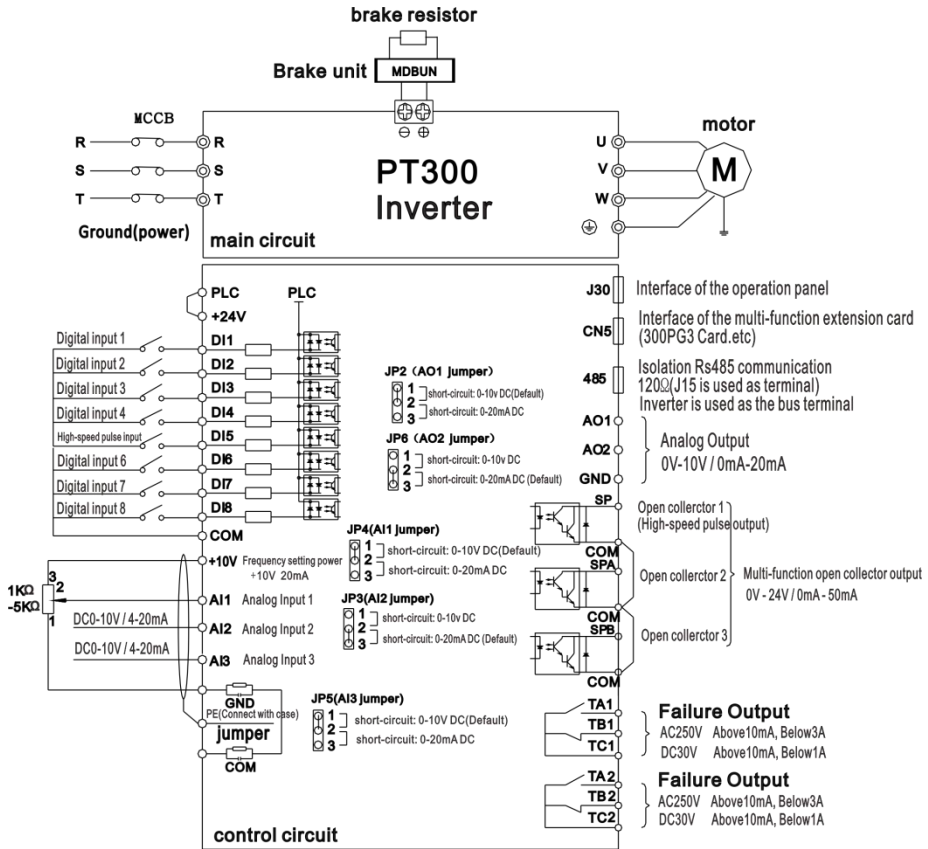

Pic3-4 Wiring diagram above 22KW(3N2~3N8/2N9~2N10)

Chapter 3 Installation and spare circuit

3-4. Main circuit terminals

3-4-1. PT300/PT360 Main circuit terminals

1. PT300/PT360: Main circuit terminals below 18.5KW (380V)

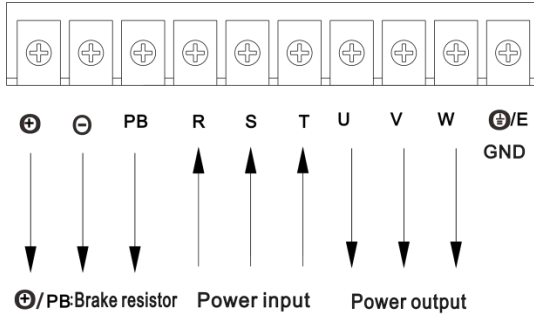

2. PT310: Main circuit terminals below 7.5KW (380V)

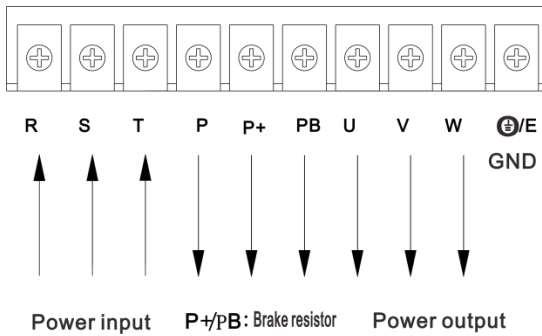

3. PT300/PT360: 22KW~37KW(380V) Main circuit terminals

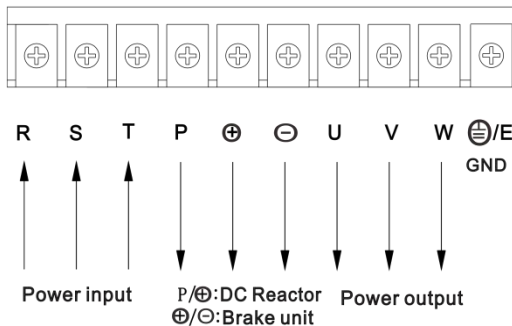

4. PT300/PT360: 45KW~55KW(380V) Main circuit terminals

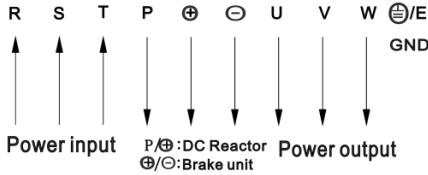
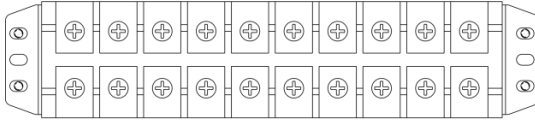

5. PT300/PT360 75KW~132KW (380V) Main circuit terminals

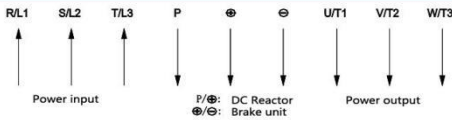
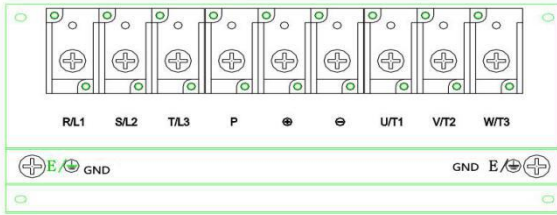

6. PT300/PT360: 160KW~450KW(380V) Main circuit terminals

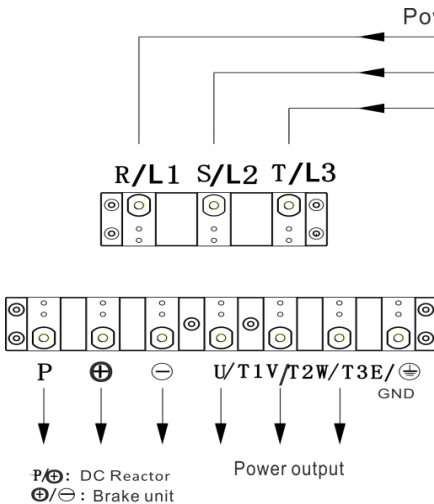

Note: P ⊕ the standard configuration is of short circuit status; If connecting a DC reactor, please first disconnect the terminals and then connect again.

Chapter 3 Installation and spare circuit

7.PT300: 450~630kW(380V) Main circuit terminals

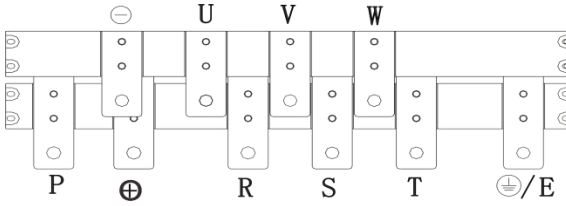

3-4-2.Description of cabling terminal functions.

Terminal	Name	Description
R/L1 S/L2 T/L3	inverter power supply input terminals	Connect to 3-phase AC power supply , and single phase AC power connect to L1, L2 terminal
⊕/E	Grounding terminal	Connect to Ground.
U/T1 V/T2 W/T3	inverter output terminals	Connect to a 3-phase motor
⊕ , PB/ ⊖	Connecting terminals of brake resistor or brake unit	Connect to the brake resistor or brake unit
P, ⊕	Connecting terminals of DC reactor	Connect to an DC reactor (Remove the short jumper bar)

3-5. Control circuit terminals

3-5-1.Terminal arrangement of control circuit

1.300SCB control circuit terminals

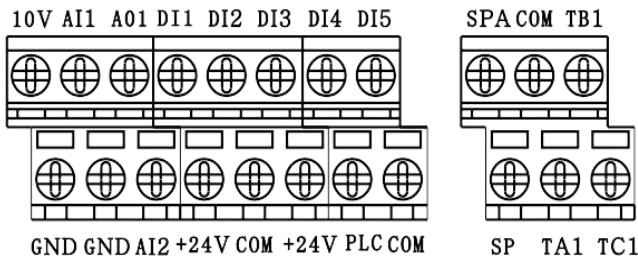

2.300LCB control circuit terminals

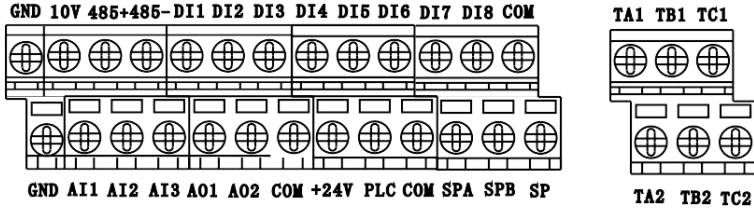

3-5-2. Description of control circuit terminals

Type	Terminal	Name	Function Description
Input signal	DI1~DI4 DI6~DI8	DI1~DI4 DI6~DI8 Digital input terminal	1.Optical coupling isolation, compatible with dual polarity input . 2.Impedance : 2.4KΩ. 3.Voltage range for level input: 9-30V. Drain drive: PLC connects to 24V DC or external power. Source drive: PLC connect to COM.
	DI5	High-speed pulse input terminal	Besides the features of DI1~DI4 and DI6~DI8, it can be used for high-speed pulse input. Maximum input frequency is : 100KHz.
Auxiliary power	+24V	Positive port of the power	Maximum output : +24V/200mA, in no conditions can short connect COM with GND.
	COM	Common port	
Output signal	SPA/COM SPB/COM	Digital output 1	Optical coupling isolation, dual polarity open-collector output. Input voltage range: 0-24V. Output current range: 0-50mA. (24V DC/150mA) COM is the common terminal, output function.
	SP/COM	High-speed pulse output terminal	It is limited by P06.00 "SP terminal output mode selection", as high-speed pulse output , the maximum frequency hits 100KHz.As open-collector output, its specification is the same as that of SPA and SPB.
	TA1/TB1/TC1 TA2/TB2/TC2	output signal 3	Contact driving capacity : AC250V, 3A, COSΦ=0.4 DC30V, 1A TA1→TC1 ON, TB1→TC1 NC. TA2→TC2 ON, TB2→TC2 NC.

Chapter 3 Installation and spare circuit

Type	Terminal	Name	Function Description
Analog Input/ Output signal	10V→GND	Analog power	Provide 10V power supply to external unit, the maximum output current : 10mA It provide power supply to external potentiometer with resistance range of 1KΩ-5KΩ
	AI1	Multi-function analog input signal 1	1. JP4 1-2 short circuit: 0- 10V input. 2. JP4 2-3 short circuit: 0- 20mA input. 3.Impedance : 22kΩ(voltage input), 500Ω(current input)
Analog Input/ Output signal	AI2	Multi-function analog input signal 2	1. JP3 1-2 short circuit: 0- 10V input. 2. JP3 2-3 short circuit: 0- 20mA input. 3.Impedance : 22kΩ(voltage input), 500Ω(current input)
	AI3	Multi-function analog input signal 3	1. JP52 1-2 short circuit: 0- 10V input. 2. JP52 2-3 short circuit: 0- 20mA input. 3.Impedance: 22kΩ(voltage input), 500Ω(current input)
	AO1, AO2	Multi-function analog output signal	1.JP2(AO1), JP41(AO2) 1-2 short circuit: 0- 10V. 2.JP2(AO1), JP41(AO2) 2-3 short circuit: 0- 20mA.
Auxiliary interface	CN5	Extension card interface	38-pin terminal , Optical external extension card(300EX_CARD, 300IO1, 300IO2, 300PLC1, 300PG1, 300PG2, 300RS485 extension card) interface .
	J30	Operation panel interface	Connect to internal /external operation panel interface.

3-6. Wiring Precautions

- ※ Input phase capacitors or surge absorbers can not be installed at the output side of the inverter. The power supply must be switch off when replace the motors.
- ※ Please do not fall the metal powder or wire end into the inverter, or it will cause fault.
- ※ Motor or power supply switchover can be performed when the inverter output stops.
- ※ In order to minimize electromagnetic interference, when the electromagnetic contactor or relay which being used are close to the inverter, a surge absorbing device should be installed.
- ※ The external control line of inverter should add isolated device or use shield cable.
- ※ The connection of the input command signal should be wiring alone besides shield , and had better far away from the main circuit wiring.
- ※ The maximum distance between the inverter and the motor is within 50m when the carrier frequency is less than 3khz; When the carrier frequency is more than 4khz, the distance should be decreased properly, and the connections had better be laid in the metal tube.
- ※ Use a 1000V mega-Ohm to test insulation resistance to ground first when an external equipment is added to the inverter such as filter and reactor , ensure that the insulation resistance is not less than 4 MΩ.

- ※ Please do not switch off the power supply when the inverter needs to start or stop frequently, and the start or stop operation must be controlled by terminal command 、 operation panel command or RS485 communication command, in order not to damage the AC rectifier .
- ※ Please do not connect the AC power supply to the output terminals U、V、W of the inverter.
- ※ The ground terminal must be grounded reliably (grounding resistance should be less than 100 ohm) in case of accidents, otherwise there will be leakage condition occurs.
- ※ In order to prevent accidents, the grounding terminals(⏏) must be grounded reliably(grounding resistance)
- ※ Select the proper wiring diameter according to the National Electrical Code when performing the main circuit wiring.
- ※ The motor capacity should be equal or less than the inverter's capacity.

3-7. Backup Circuits

It will cause great loss or other unexpected fault when the inverter has a fault. To avoid this situation happen, please add the backup circuit of the diagram below to ensure the safety.

Note: Running characteristics of the backup circuit must be tested beforehand to ensure that the power frequency and variable frequency are of the same phase sequence.

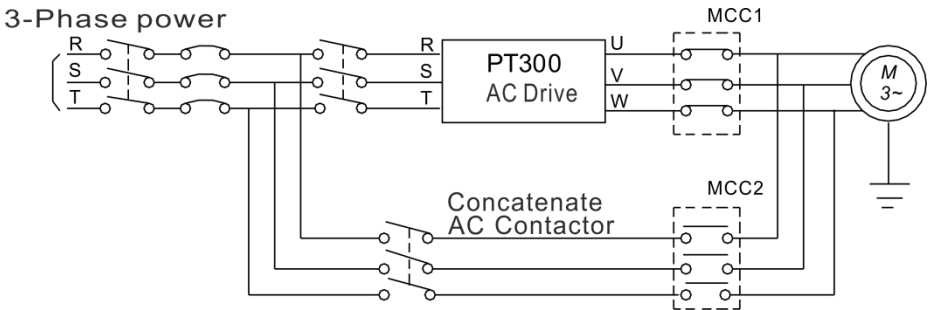

Pic 3-5 Backup circuits

Chapter 4 Operation Panel

Chapter 4 Operation Panel

4-1. Operation panel introduction



JP6E300 Operation panel

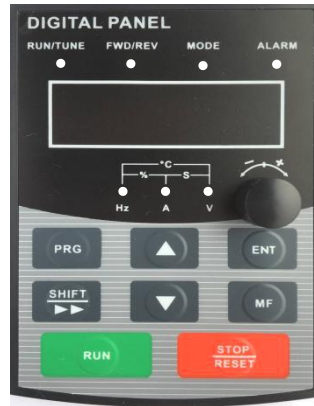

JP6E300V2 Keyboard control panel





Pic 4-1 Operation panel display

4-2. Description of indicators









Indicator symbols		Name	Units display	Meanings	Color
Lamp	RUN/TUNE	Run indicator		ON: inverter is in running state OFF: inverter is in stop state Twinkle: inverter is in Auto-turning state	Green
	FWD/REV	FWD rotation indicator		ON: FWD rotation state OFF: Rev rotation state	Green
	MODE	Communication indicator		Operation panel, terminal and communication control indicator ON: communication control OFF: operation panel control Twinkle: terminal control	Green
	ALARM	Fault indicator		ON: inverter is faulty OFF: inverter is normal Flicker: inverter previous two faults is not confirmed	Red

Indicator symbols		Name	Units display	Meanings	Color
Unit Lamp	Hz	Frequency indicator	Hz	ON: the current displayed parameter is running frequency OFF: the current displayed parameter is setting frequency	Green
	A	Current indicator	A	ON: the current displayed parameter is the current	Green
	V	Voltage indicator	V	ON: the current displayed parameter is the voltage	Green
	Hz+A	Percentage indicator	%	ON: the current displayed parameter is the percentage	Green
	A+V	Time indicator	s	ON/Flicker: the current displayed parameter is user-defined parameter	Green
	Hz+V	Temperature indicator	℃	ON: the current displayed parameter is the temperature	Green
	Hz+A+V		RPM indicator	RPM	ON: the current displayed parameter is the RPM
		No-unit indicator		OFF: the current displayed	Green

4-3. Description of keys on the operation panel

Key	Name	Function
	Confirm	* Enter the menu level by level, and confirm the parameter setting .
	Shift	* In level-3, use  to modify the function code data bit. * Select the displayed parameters in turn
	FWD/REV switchover	* JOG running * FWD / Rev switchover * Clear the settings of clockwise rotation to Increase / anticlock rotation to Decrease.
	Programmin g	* Enter or Exit the level-1 menu.

Chapter 4 Operation Panel

Key	Name	Function
	RUN	* Start the inverter in operation panel control mode
	Stop/Reset	* inverter stops running * Reset when inverter is abnormal * Fault confirm
	Increment key	Increment of data or function code
	Decrement key	Decrease in data or function code
	clockwise rotation to increase +	* The First-level menu, the function code P00-P30 increase * The Second-level menu, the function code increase. * The Three-level menu, the function code increase. * When STOP/RUNNING, frequency reference or closed loop reference increase
	anticlockwise rotation to Decrease -	* The First-level menu, the function code P00-P30 decrease * The Second-level menu, the function code decrease * The Three-level menu, the function code decrease *When STOP/RUNNING, frequency reference or closed loop reference decrease
		*  Press this Key, the action the same to press PRG

4-4. Menu style

The operation panel adopts three-level style, consists of:

- 1) Function code group (level-1)
- 2) Function code (level-2)
- 3) Function code setting value (level-3)

4-4-1. Structure of level-1 menu

● Structure of level-1 menu

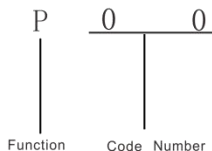

Pic 4-2 Structure of level-1 menu

●Description of level-1 zone

Password function zone	Function code zone	Group number	Function code range
User-password protected zone (P00-P30)	User operate zone(P00-P30)	P00 Group	P00.00~P00.64
		P01 Group	P01.00~P01.28
		P02 Group	P02.00~P02.37
		P03 Group	P03.00~P03.22
		P04 Group	P04.00~P04.16
		P05 Group	P05.00~P05.39
		P06 Group	P06.00~P06.22
		P07 Group	P07.00~P07.15
		P08 Group	P08.00~P08.14
		P09 Group	P09.00~P09.49
		P10 Group	P10.00~P10.70
		P11 Group	P11.00~P11.32
		P12 Group	P12.00~P12.09
		P13 Group	P13.00~P13.51
		P14 Group	P14.00~P14.00
		P15 Group	P15.00~P15.31
		P17 Group	P17.00~P17.04
		P18 Group	P18.00~P18.08
		P19 Group	P19.00~P19.21
		P20 Group	P20.00~P20.65
P21 Group	P21.00~P21.65		
P22 Group	P22.00~P22.65		
P23 Group	P23.00~P23.12		
P24 Group	P24.00~P24.29		
P25 Group	P25.00~P25.09		
P26 Group	P26.00~P26.07		
P27 Group	P27.00~P27.06		
P30 Group	P30.00~P30.19		
Password protected zone of manufacture	User-defined function code hidden zone (P16)	P16 Group	

Chapter 4 Operation Panel

4-4-2. Structure of level-2 menu

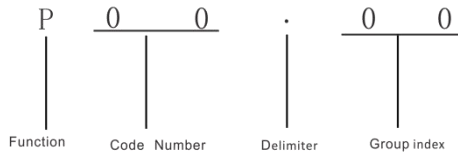

Pic 4-3 Level-2 menu

●Level-2 data display/Setting format

Display/Setting with decimal: data bit: 1~5 The symbols which can be displayed or set is : 0~9.

4-4-3. Structure of level-3 menu

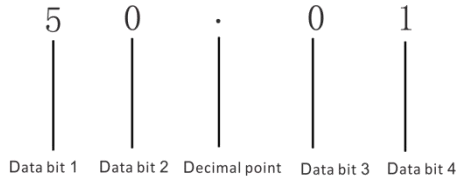

Pic 4-4 level-3 menu format

4-4-4. Common symbols of LED display

In addition to the function code level-1、level-2 and level-3 menu , the operation panel will always display some remind symbols in using process, see the table below:

Remind symbol	Meanings	Remind symbol	Meanings
PT300	The inverter will display PT300 when power-on, which indicates it is PT300 production	E.PHI	Input power phase loss
E.oC1	Overcurrent during acceleration	E.PHo	Output power phase loss
E.oC2	Overcurrent during deceleration	E.oH1	Rectifier module overheat fault
E.oC3	Overcurrent at constant speed	E.SET	External fault
E.oU1	Overvoltage during acceleration	E.CE	Communication fault
E.oU2	Overvoltage during deceleration	E.CoN	Contactor fault
E.oU3	Overvoltage at constant speed	E.oCC	Current detection fault
E.Br	Buffer resistor overload fault	E.Enco	Encoder fault
E.LU	DC-bus undervoltage	E.TE	Motor auto-turning fault
E.oL1	inverter overload	E.EEP	EEPROM R/W fault
E.oL2	Motor overload	E.INv	inverter hardware fault
E.Tov	Accumulative running time reached fault	E.PUTO	Accumulative power-on time reached fault
E.USE1	User-defined fault 1	E.STG	Motor short-circuited to ground fault
E.USE2	User-defined fault 2	E.LOAD	No-load fault

Chapter 4 Operation Panel

E.PId	PID feedback lost fault	E.CBC	Fast current limit time out fault
E.SrUN	Motor disconnected during running fault	E.SSD	Too large speed deviation fault
E.oS	Motor overspeed fault	E.OH2	Motor overheat fault
E.INIT	Initial position fault	E.tSF	Hydraulic probe damaged
A-HP	High water pressure fault	A-LL	Water shortage warning
A-LP	Low water pressure fault	A-tF	Full water warning

Note: The special display meanings of "-----" of the menu.

If there are 5-digits in addition to the displayed data when power-on, which indicates there is password protection, and needs to input the password. P16 parameter group is the reserved of manufacturer which can perform password input function .P17 group is used for user password setting .

If there are some remind symbols that are not listed in the table, please contact the Agency or Manufacturer company directly.

4-4-5.The LED display corresponding to the symbol

LED display symbols and characters/Numbers corresponding relationship is as follows:

Alphabet display	Corresponding Alphabet	Alphabet display	Corresponding Alphabet	Alphabet display	Corresponding Alphabet
0	0	1	1	2	2
3	3	4	4	5	5
6	6	7	7	8	8
9	9	A	A	b	B
C	C	d	d	E	E
F	F	H	H	l	l
L	L	n	N	n	n
o	o	P	P	r	r
S	S	t	t	U	U
u	v	T	T	-	-

4-5. Password setting











PT300 provides user password protection function , when P17.00 is set to a non-zero value , the value is the user password, the password takes effect after you exit the function code editing state, when you press PRG button again, "-----"is displayed, and you must enter the correct user password to enter the menu.

To cancel the user password protection function, enter with password and set P17.00 to 0.

4-6. Operation panel display and keys operation

4-6-1. Display status classification:

Operation panel display status is divided into 9 kinds:

Sequence	Status name	Meanings
1	Parameter display state when inverter stops	Display parameter switchover via  key, P08.03 can set the display parameters.
2	Parameter display state when inverter is running	Display parameter switchover via  key, P08.02 can set the display parameters.
3	Fault and warning display state	In another 7 display states, enter this state directly when fault occurs .
4	Level-1 menu display state	Before operation panel unlocked, press  or  encoder to enter in .
5	Level-2 menu edit state	In level-1 menu display status, Press  or  encoder to enter in .
6	Level-3 menu edit state	In level-2 menu display status, Press  or  encoder to enter in .
7	Password verification state	When it is in password protection, In level-2 menu display status , Press  or  encoder to enter in .
8	Direct parameter modify state	In stop/running parameter display status, to enter in by press encoder in clockwise rotation or anticlockwise rotation.
9	Information remind state	Refer to 4-4-5 LED display corresponding symbols.

4-6-2. Display status and operation process SHIFT key

In level-3 menu or password verification states,  key is used for data bit selection .

● **States switchover automatically**

No operation after 1 minute, automatically back to the stop parameter display status or running parameter display status.

No operation after one minutes, clear the menu editing state, back to the stop parameter display status or running parameter display status.

If there is password setting or key-locked setting, it will automatically enter password protection or operation panel locked status when no operation within 5 minutes.

● **Display status and operation process**

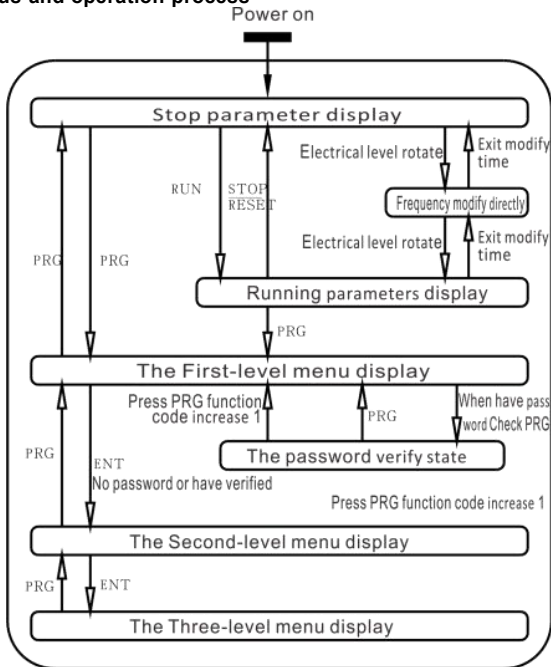

Pic 4-5 Display status and operation process

4-7. Operation example

The parameter displayed at stop is setting frequency, and the default value is 50HZ. The underline data bit in the picture means the current edit bit.

4-7-1.Recovery to factory parameter

Such as set P17.01=1:

It will set all parameters of P group to factory settings except P02 group

Chapter 4 Operation Panel

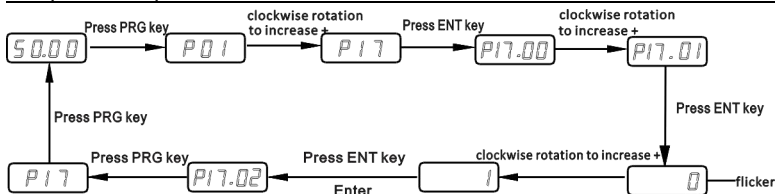

Pic 4-6 Recovery to factory parameters

4-7-2. Set setting frequency

Such as set P01.08=50Hz and modify it to 40Hz

First step : P01.03→0(default value is 0, which indicates the encoder is effective)

Second step: as bellow

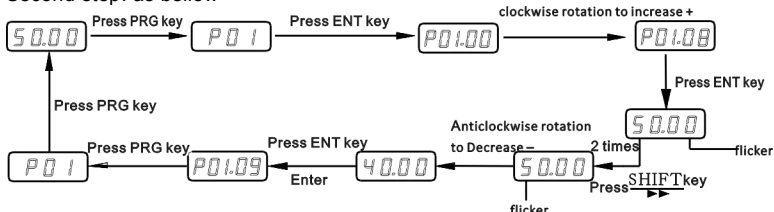

Pic 4-7 Set setting frequency

4-7-3. Password setting

Such as set the user password P17.00 to 00005

Note: It will not be effective until secondary power-on after parameter setting finished.

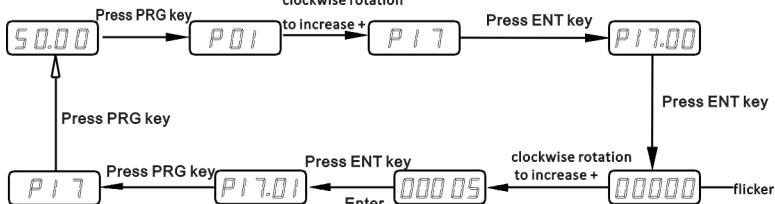

Pic 4-8 Password setting

4-7-4. Password verification

Presume that the password of the function codes that after P00.00 is protected, and the password is 00005 ,

make password protection of P00.00 effect. Password verification according to the following process .

Note: When using RS485 communication mode to password verification, please refer to the appendix of RS485 communication protocol.

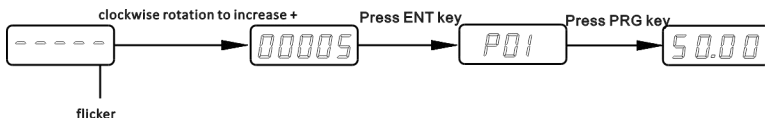

Pic 4-9 Password verification

4-7-5. Password

Such as clear user password of P17.00 .

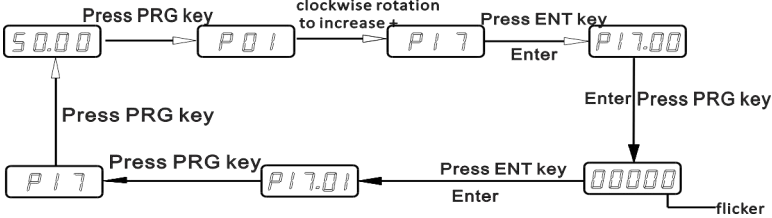

Pic 4-10 Password

4-8. Parameter setting mode

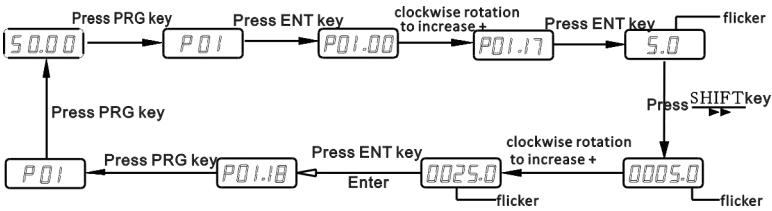

Pic 4-11 Parameter setting

Case 1: Take modify the acceleration time from 5.0 to 25.0 of P09.00 for example

1. In P00 state, rotate the encoder clockwise to increase the function code to P09.00, and the current LED displays 5.0.

2. Press 3 times the ten's digit of LED display flicker.

3. Rotate the encoder clockwise to increase the ten's digit of LED to 2

4-9. Pressure setting instructions

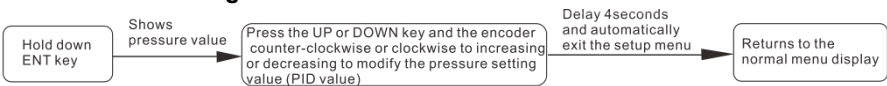

Attachment: pressure conversion relationship:

$$0.1 \text{ MPa (MPa)} = 100 \text{ KPa (kPa)} = 1 \text{ Bar (bar)} = 1 \text{ Kgf / cm2 (kgf / cm2)}$$

4-10. Multi-reference 0 source as encoder potentiometer setting description

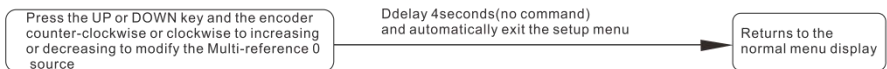

4-11. Torque control mode, the encoder settings torque value instructions

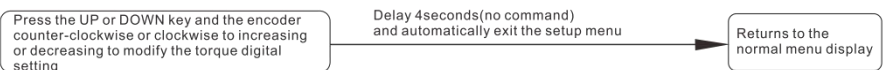

Chapter 5 Commissioning

First-time running with power on according to the following processes.

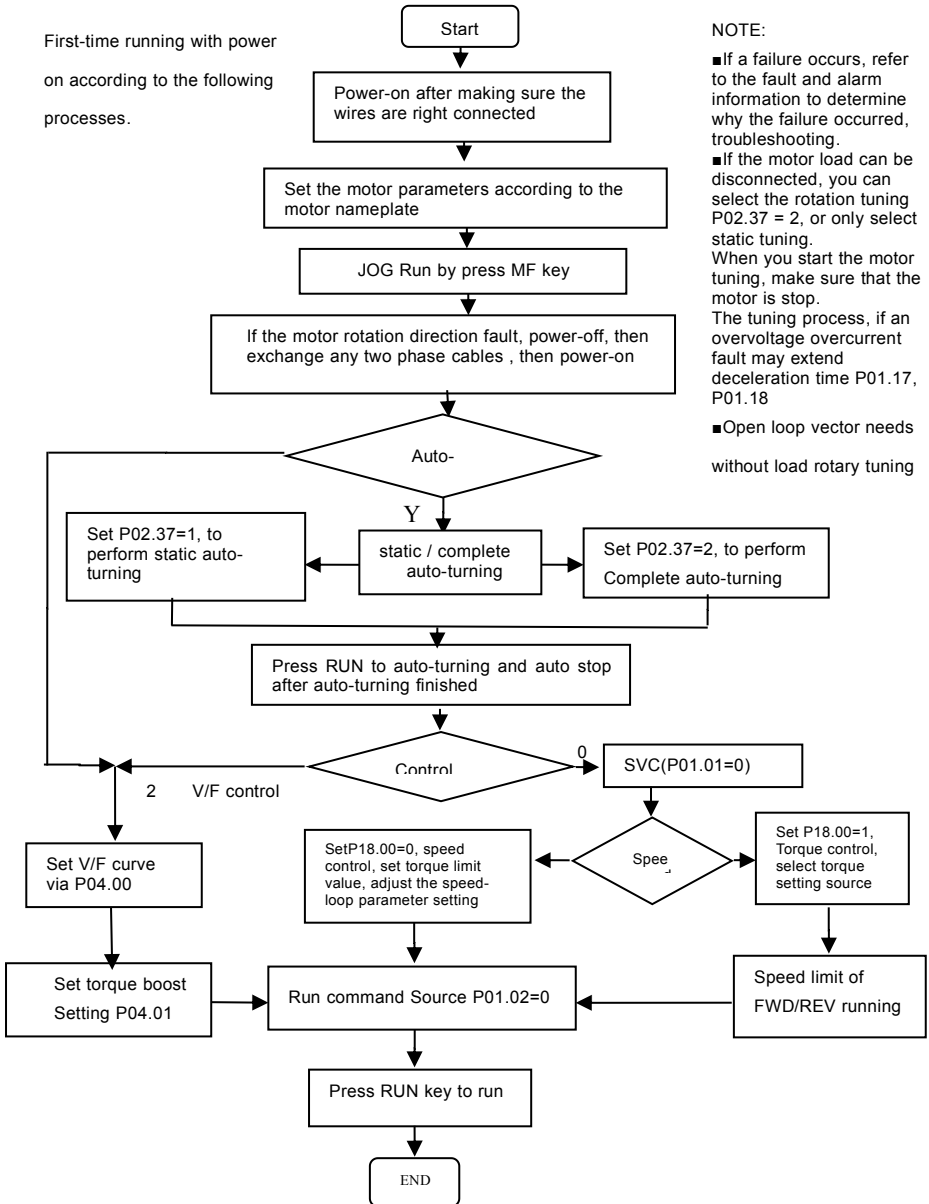

NOTE:

- If a failure occurs, refer to the fault and alarm information to determine why the failure occurred, troubleshooting.
- If the motor load can be disconnected, you can select the rotation tuning P02.37 = 2, or only select static tuning. When you start the motor tuning, make sure that the motor is stop. The tuning process, if an overvoltage overcurrent fault may extend deceleration time P01.17, P01.18
- Open loop vector needs without load rotary tuning

Pic 5-1 Commissioning

- Before connecting the main power to inverter, please confirm that the AC input power is in the range of rated motor voltage .
- Connecting the main power to R, S, T terminals of inverter.
- Select the proper running control mode.

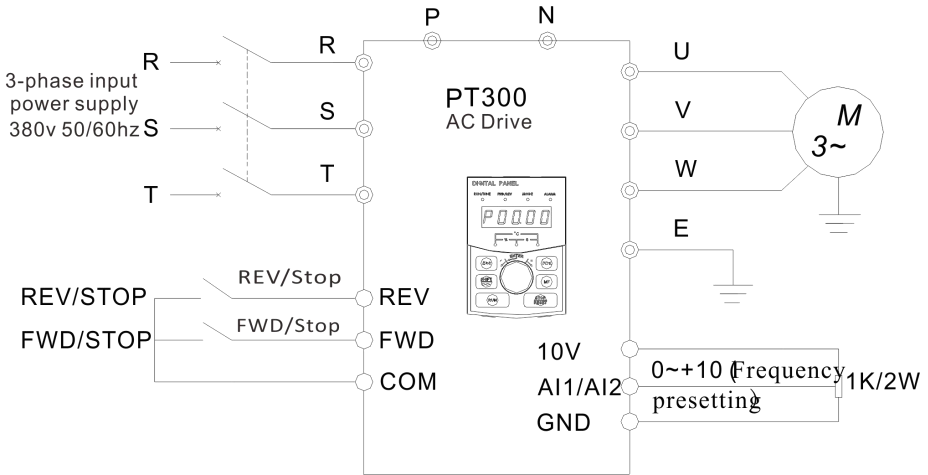

Diagram 5-2 Running control mode

For example: Analog voltage input(P01.01=2、 P01.03=2 or 3) +terminal command
(P01.02=1、 P05.00=1、 P05.01=2) ;

Frequency command is set via AI1/AI2 terminal, FWD/REV is controlled by DI1 and DI2.

For example: The operation panel control of speed(P01.01=2、 P01.03=0) + Switchover between
FWD and REV running(P08.01=2)

Frequency is set by means of the encoder of the operation panel to acceleration by clockwise and deceleration by anticlockwise, switchover between FWD and REV running by press MF button on operation panel.

- ※ No-load running and check the speed adjustment .
- ※ Confirm the minimum and the Maximum output frequency setting.
- ※ Check JOG running control.
- ※ Confirm Acc/Dec time.
- ※ Connect the motor.
- ※ Running at low-speed and check the motor rotating direction.
- ※ Check whether the display and output are right during all operation process.

Chapter 6 Function Code Table

Chapter 6 Function Code Table

Function of PT300 series Inverters can be divided into 30 groups, namely P00~P30 according to the function; and every function group includes several function codes. The function code adopts three-level menu; for example, P08.08 means the eighth function code in P08 function group ; and P16 is the manufacturer's function parameter and the user has no right to visit the parameter in this group.

In order to make convenience for the setting of function code, group number of the function, number of function code and parameter of function code respectively corresponds with the first-level menu, the secondary menu and three-level menu when the operation panel is used for operation.

1. The content in the line of menu is as following:

The first line "NUMBER": it is the serial number for this function code in the whole function code; meanwhile, it also shows the register address for the communication.

The second line "CODE": it is the serial number for the parameter group of the function and parameter.

The third line "DESCRIBING LED/OLED KEYBOARD DISPLAY": it is the detailed description of this function parameter.

The fourth line: "SETTING RANGE" : it is the effective setting range of the function parameter and it is shown on LED / OLED operation panel.

The fifth line "FACTORY SETTING": it is the original set value for the function parameter when it leaves the factory;(P00 group do not have this parameter)

The sixth line "ALTERATION": it is the alternative attributive of the function parameter (i.e. whether it allows alternation and alternating condition); and the inverter is as follow:

"◇" shows the set value of the parameter can be alternated whenever the Inverter is stopped or operated;

"□"shows the set value of the parameter can't be alternated when the Inverter operated;

"■" shows the value of the parameter is actual record value of the detection; and it can't be changed; (the Inverter has made an automatic check and restriction on alternative attributive of every parameter and it can help the user to avoid wrong alternation.)

2. "Parameter system" is decimal system(DEC); if the parameter is shown via hexadecimal, every data is independent mutually when the parameter is edited; value range of partial bits can be hexadecimal (0~F).

3. "Factory setting" shows the value after the parameter of the function code is updated when the operation of recovering factory parameter; parameter or record value of actual detection can't be updated.

4. In order to protect the parameter more effectively, the Inverter provides password protection for the function code. After the user password is set(namely, parameter for user password P07.00 is not 0) , the system will firstly enter into the state of user password authentication when the user press  enter into the editing state of the function code; and then what is shown is"-----" the operator must input user password correctly, or the user can't enter. It is unnecessary to input manufacturer's password correctly for

the parameter zone set the manufacturer. (warning: the user can NOT try to change the parameter set by the manufacturer; if the parameter is not set properly, it will easily cause the abnormal work or even destroy of the Inverter). The user password can be changed randomly under the condition that the password protection is unlocked; the user password is subject to the value input last. Set P07.00 to 0 can cancel the user password; if P07.00 is not 0 when electrify, then it shows the parameter is protected by password.

5.Function of user password also follows the above principle when the serial communication is used to change the parameter of the function code.

Group P00: Monitoring Parameters

Function Code	LED/OLED Operation panel display	Setting range	Modify	Address
P00.00	Running Frequency(Hz)	0-500.00Hz	■	7000
P00.01	Set Frequency(Hz)	0-500.00Hz	■	7001
P00.02	Bus Voltage (V)	0-3000V	■	7002
P00.03	Output Voltage(V)	0-1140V	■	7003
P00.04	Output Current(A)	0-655.35A	■	7004
P00.05	Output Power(KW)	0-32767KW	■	7005
P00.06	Output Torque(%)	-200.0%-200.0%	■	7006
P00.07	DI1-DI8 Input State	0-32767	■	7007
P00.08	SPA, SPB Output State	0-1023	■	7008
P00.09	AI1 Voltage(V)	0-10.57V 0-20.000mA	■	7009
P00.10	AI2 Voltage(V)	0-10.57V 0-20.000mA	■	700A
P00.11	AI3 Voltage(V)	0-10.57V 0-20.000mA	■	700B
P00.12	Count Value	0-65535	■	700C
P00.13	Length Value	0-65535	■	700D
P00.14	Load Speed	0-65535	■	700E
P00.15	PID Setting	0-100.0bar(kg)	■	700F
P00.16	PID Feedback	0-100.0bar(kg)	■	7010
P00.17	PLC Stage	0-16	■	7011
P00.18	Input Pulse Frequency(Hz)	0-100.00KHz	■	7012
P00.19	Feedback Speed(0.1Hz)	-500.00Hz-500.00Hz	■	7013
P00.20	Remaining Running Time	0-65535Min	■	7014

Chapter 6 Function Code Table

Function Code	LED/OLED Operation panel display	Setting range	Modify	Address
P00.21	AI1 voltage before correction	0-10.57V 0-20.000mA	■	7015
P00.22	AI2 voltage before correction	0-10.57V 0-20.000mA	■	7016
P00.23	AI3 voltage before correction	0-10.57V 0-20.000mA	■	7017
P00.24	Linear Speed	0-65535m/Min	■	7018
P00.25	Accumulative Power-on Time	0-65535Min	■	7019
P00.26	Accumulative Running Time	0-65535Min	■	701A
P00.27	Pulse Input Frequency	0-65535Hz	■	701B
P00.28	Communication Setting Value	-100.0%-100.0%	■	701C
P00.29	Encoder Feedback Speed	0-65535Hz	■	701D
P00.30	Main Frequency X	0-500.00Hz	■	701E
P00.31	Auxiliary Frequency Y	0-500.00Hz	■	701F
P00.32	Viewing any Register Address Value	-	■	7020
P00.33	Synchronous Motor Rotor Position	-	■	7021
P00.34	Motor Temperature	0-200℃	■	7022
P00.35	Target Torque(%)	-200.0%-200.0%	■	7023
P00.36	Resolver Position	0-4095	■	7024
P00.37	Power Factor angle	-	■	7025
P00.38	ABZ position	0-65535	■	7026
P00.39	Target Voltage Upon V/F Separation	0-Rated motor voltage	■	7027
P00.40	Output Voltage Upon V/F Separation	0- Rated motor voltage	■	7028
P00.41	DI state visual display	-	■	7029
P00.42	DO state visual display	-	■	702A
P00.43	DI function state visual display 1	-	■	702B
P00.44	DI function state visual display 2	-	■	702C

Chapter 6 Function code table

Function Code	LED/OLED Operation panel display	Setting range	Modify	Address
P00.45	Fault Information	-	■	702D
P00.46	Reserved	-	■	702E
P00.47	Reserved	-	■	702F
P00.48	Reserved	-	■	7030
P00.49	Reserved	-	■	7031
P00.50	Reserved	-	■	7032
P00.51	Reserved	-	■	7033
P00.52	Reserved	-	■	7034
P00.53	Reserved	-	■	7035
P00.54	Reserved	-	■	7036
P00.55	Reserved	-	■	7037
P00.56	Reserved	-	■	7038
P00.57	Reserved	-	■	7039
P00.58	Phase Z Counting	0-65535	■	703A
P00.59	Current Setting Frequency	-100.00%-100.00%	■	703B
P00.60	Current Running Frequency	-100.00%-100.00%	■	703C
P00.61	inverter Running State	0-65535	■	703D
P00.62	Current Fault Code	0-99	■	703E
P00.63	Sent Value Of Point-Point Communication	-100.00%-100.00%	■	703F
P00.64	Received Value Of Point- Point Communication	0-63	■	7040

Chapter 6 Function Code Table

Group P01: Basic Parameters

Function Code	LED/OLED Operation panel display	Setting range	Factory settings	Modify	Address
P01.00	G/P type display	1: G type(constant torque load) 2: P type (variable torque load e.g.fun and pump) PT300 this parameter is modifiable PT360 this parameter is read only	1	□	F000
P01.01	Motor 1 control mode	0: Sensorless Vector Control (SVC) 1: Closed-Loop Vector Control(FVC) 2: Voltage/Frequency Control(VF)	2	□	F001
P01.02	Command source selection	0: operation panel control(LED OFF) 1: terminal control(LED ON) 2: communication control (LED blinking) 3: According to water inlet pressure start the command channel 4: When power on, automatically run command channel	0	◇	F002
P01.03	Main frequency source X selection	0: Digital setting(Preset Frequency is P01.08 UP/DOWN can be modified, non-retentive at power failure) 1: Digital setting(Preset Frequency is P01.08, UP/DOWN can be modified, retentive at power failure) 2: Digital setting(Preset Frequency is P01.08, non-retentive at power failure) 3: Digital setting(Preset Frequency is P01.08, retentive at power failure) 4: AI1 5: AI2 6: AI3 7: Pulse setting(DI5) 8: Multi-reference 9: Simple PLC 10: PID 11: communication setting	0	□	F003
P01.04	Auxiliary frequency source Y selection	The same as P01.03 (Main frequency source X selection)	0	□	F004

Chapter 6 Function code table

Function Code	LED/OLED Operation panel display	Setting range	Factory settings	Modify	Address
P01.05	Range selection of auxiliary frequency Y for X and Y operation	0: Relative to maximum frequency 1: Relative to main frequency X	0	◇	F005
P01.06	Range of auxiliary frequency Y for X and Y operation	0%~100%	100%	◇	F006
P01.07	Frequency source selection	Unit's digit: Frequency source selection 0: Main frequency source X 1: X and Y operation (operation relationship determined by ten's digit) 2: Switchover between X and Y 3: Switchover between X and "X and Y operation" 4: Switchover between Y and "X and Y operation" Ten's digit: X and Y operation relationship 0: X+Y 1: X-Y 2: Maximum 3: Minimum 4: Main * auxiliary / maximum frequency	00	◇	F007
P01.08	Preset frequency	0.00Hz~Maximum frequency(P01.10)	50.00Hz	◇	F008
P01.09	Rotation direction	0: Same direction 1: Reverse direction	0	◇	F009
P01.10	Maximum frequency	50.00Hz~500.00Hz	50.00Hz	□	F00A
P01.11	Source of frequency upper limit	0: Set by P01.12 1: AI1 2: AI2 3: AI3 4: Pulse setting 5: Communication setting	0	□	F00B
P01.12	Frequency upper limit	Frequency lower limitP01.14~Maximum frequency P01.10	50.00Hz	◇	F00C
P01.13	Frequency upper limit offset	0.00Hz~Maximum frequency P01.10	0.00Hz	◇	F00D
P01.14	Frequency lower limit	0.00Hz~Frequency upper limit P01.12	0.00Hz	◇	F00E

Chapter 6 Function Code Table

Function Code	LED/OLED Operation panel display	Setting range	Factory settings	Modify	Address
P01.15	Carrier frequency	0.5kHz~16.0kHz	Model dependent	◇	F00F
P01.16	Carrier frequency adjustment with temperature	0: No 1: Yes	1	◇	F010
P01.17	Acceleration time 1	0.0s~6500.0s	Model dependent	◇	F011
P01.18	Deceleration time 1	0.0s~6500.0s	Model dependent	◇	F012
P01.19	Acceleration/Deceleration time unit	0: 1s 1: 0.1s 2: 0.01s	1	□	F013
P01.20	Auto running time delay setting	0.0s~3600.0s	10.0s	◇	F014
P01.21	Frequency offset for auxiliary frequency source X and Y operation	0.00Hz~maximum frequency P01.10	0.00Hz	◇	F015
P01.22	Frequency reference resolution	1: 0.1Hz 2: 0.01Hz	2	□	F016
P01.23	Stop memory selection of digital set frequency	0: Not memory 1: memory	1	◇	F017
P01.24	Motor selection	0: Motor `1 1: Motor `2 2: Motor `3 3: Motor `4	0	□	F018
P01.25	Acceleration/Deceleration time base frequency	0: Maximum frequency(P01.10) 1: Set frequency 2: 100Hz	0	□	F019
P01.26	Base frequency for UP/DOWN modification during running	0: Running frequency 1: Set frequency	0	□	F01A
P01.27	Binding command source to frequency source	Unit's digit : Binding operation panel command to frequency source 0: No binding 1: Frequency source by digital setting	0000	◇	F01B

Chapter 6 Function code table

Function Code	LED/OLED Operation panel display	Setting range	Factory settings	Modify	Address
		2: AI1 3: AI2 4: AI3 5: Pulse setting(DI5) 6: Multi-reference 7: Simple PLC 8: PID 9: Communication setting Ten's digit: Binding terminal command to frequency source Hundred's digit: Binding communication command to frequency source Thousand's digit: Binding auto-running to frequency source			
P01.28	Communication card type	0: Modbus communication card 1: Profibus-DP communication card 2: CANopen communication card 3: CANlink communication card	0	◇	F01C

Group P02: Motor 1 Parameters

Function Code	LED/OLED Operation panel display	Setting range	Factory settings	Modify	Address
P02.00	Motor type selection	0: common asynchronous motor 1: variable frequency asynchronous motor 2: permanent magnetic synchronous motor	0	□	F100
P02.01	Rated motor power	0.1KW~1000.0KW	Model dependent	□	F101
P02.02	Rated motor voltage	1V~2000V	Model dependent	□	F102
P02.03	Rated motor current	0.01A~655.35A (inverter Power<=55KW) 0.1A~6553.5A (inverter Power>55KW)	Model dependent	□	F103
P02.04	Rated motor frequency	0.01Hz~Maximum Frequency	Model dependent	□	F104
P02.05	Rated motor rotational speed	1rpm~6553rpm	Model dependent	□	F105
P02.06	stator resistance (asynchronous)	0.001Ω~65.535Ω (inverter Power<=55KW)	Tune parameter	□	F106

Chapter 6 Function Code Table

Function Code	LED/OLED Operation panel display	Setting range	Factory settings	Modify	Address
	motor)	0.0001Ω~6.5535Ω (inverter Power>55KW)			
P02.07	rotor resistance (asynchronous motor)	0.001Ω~65.535Ω (inverter Power<=55KW) 0.0001Ω~6.5535Ω (inverter Power>55KW)	Tune parameter	<input type="checkbox"/>	F107
P02.08	leakage inductive Reactance (asynchronous motor)	0.01mH~655.35mH (inverter Power<=55KW) 0.001mH~65.535mH (inverter Power>55KW)	Tune parameter	<input type="checkbox"/>	F108
P02.09	mutual inductive Reactance (asynchronous motor)	0.1mH~6553.5mH (inverter Power<=55KW) 0.01mH~655.35mH (inverter Power>55KW)	Tune parameter	<input type="checkbox"/>	F109
P02.10	No load current (asynchronous motor)	0.01A~P02.03(inverter Power<=55KW) 0.1A~P02.03(inverter Power>55KW)	Tune parameter	<input type="checkbox"/>	F10A
P02.16	stator resistance (synchronous motor)	0.001Ω~65.535Ω (inverter Power<=55KW) 0.0001Ω~6.5535Ω (inverter Power>55KW)	Tune parameter	<input type="checkbox"/>	F110
P02.17	shaft D inductance (synchronous motor)	0.01mH~655.35mH (inverter Power<=55KW) 0.001mH~65.535mH (inverter Power>55KW)	Tune parameter	<input type="checkbox"/>	F111
P02.18	shaft Q inductance (synchronous motor)	0.01mH~655.35mH (inverter Power<=55KW) 0.001mH~65.535mH (inverter Power>55KW)	Tune parameter	<input type="checkbox"/>	F112
P02.20	Back EMF (synchronous motor)	0.0V~6553.5V	Tune parameter	<input type="checkbox"/>	F114
P02.27	Encoder pulses per revolution	1~65535	1024	<input type="checkbox"/>	F11B
P02.28	Encoder type	0: ABZ incremental encoder 1: UVW incremental encoder 2: Resolver 3: SIN/COS encoder 4: Wire-saving UVW encoder	0	<input type="checkbox"/>	F11C
P02.30	AB phase sequence of ABZ incremental encoder	0: Forward 1: Reverse	0	<input type="checkbox"/>	F11E
P02.31	Encoder installation angle		0.0°	<input type="checkbox"/>	F11F

Chapter 6 Function code table

Function Code	LED/OLED Operation panel display	Setting range	Factory settings	Modify	Address
		0.0~359.9°			
P02.32	UVW phase sequence of UVW encoder	0: Forward 1: Reverse	0	□	F120
P02.33	UVW encoder angle offset	0.0~359.9°	0.0°	□	F121
P02.34	Number of pole pairs of resolver	1~65535	1	□	F122
P02.36	Encoder wire-break detection time	0.0s: No action 0.1s~10.0s	0.0s	□	F124
P02.37	Auto-turning selection	0: No auto-turning 1: Asynchronous motor static auto-turning 2: Asynchronous motor complete auto-turning 11: Synchronous motor static auto-turning 12: Synchronous motor complete auto-turning	0	□	F125

Group P03: Motor 1 Vector Control Parameters

Function Code	LED/OLED Operation panel display	Setting range	Factory settings	Modify	Address
P03.00	Speed loop proportional gain 1	1~100	30	◇	F200
P03.01	Speed loop integral time 1	0.01s~10.00s	0.50s	◇	F201
P03.02	Switchover frequency 1	0.00~P03.05	5.00Hz	◇	F202
P03.03	Speed loop proportional gain 2	1~100	20	◇	F203
P03.04	Speed loop integral time 2	0.01s~10.00s	1.00s	◇	F204
P03.05	Switchover frequency 2	P03.02~Maximum frequency	10.00Hz	◇	F205
P03.06	Vector control slip gain	50%~200%	100%	◇	F206

Chapter 6 Function Code Table

Function Code	LED/OLED Operation panel display	Setting range	Factory settings	Modify	Address
P03.07	Time constant of speed loop filter	0.000s~0.100s	0.050s	◇	F207
P03.08	Vector control over-excitation gain	0~200	64	◇	F208
P03.09	Torque upper limit source in speed control mode	0: Set by function code P03.10 1: AI1 2: AI2 3: AI3 4: Pulse setting 5: communication setting 6: MIN(AI1, AI2) 7: MAX(AI1, AI2) The full range of 1-7 options corresponds to P03.10	0	◇	F209
P03.10	Digital setting of torque upper limit in speed control mode	0.0%~200.0%	150.0%	◇	F20A
P03.13	Excitation adjustment proportion gain	0~60000	2000	◇	F20D
P03.14	Excitation adjustment integral gain	0~60000	1300	◇	F20E
P03.15	Torque adjustment proportion gain	0~60000	2000	◇	F20F
P03.16	Torque adjustment integral gain	0~60000	1300	◇	F210
P03.17	Speed loop integral property	Unit's digit: Integral separation 0: Invalid 1: Valid	0	◇	F211
P03.18	Field weakening mode of synchronous motor	0: No field weakening 1: Direct calculation 2: Automatic adjustment	1	◇	F212
P03.19	Field weakening depth of synchronous motor	50%~500%	100%	◇	F213
P03.20	Maximum field weakening current	1%~300%	50%	◇	F214

Chapter 6 Function code table

Function Code	LED/OLED Operation panel display	Setting range	Factory settings	Modify	Address
P03.21	Field weakening automatic adjustment gain	10%~500%	100%	◇	F215
P03.22	Field weakening integral multiple	2~10	2	◇	F216

Group P04: V/F Control Parameters

Function Code	LED/OLED Operation panel display	Setting range	Factory settings	Modify	Address
P04.00	VF curve setting	0: Linear V/F 1: Multi-point V/F 2: Square V/F 3: 1.2 power V/F 4: 1.4 power V/F 6: 1.6 power V/F 8: 1.8 power V/F 9: Reserved 10: VF complete separation 11: VF half separation	0	□	F300
P04.01	Torque boost	0.0%: (Automatic torque boost) 0.1%~30.0%	0.0%	◇	F301
P04.02	Cut-off frequency of torque boost	0.00Hz~maximum frequency	50.00Hz	□	F302
P04.03	Multi-point VF frequency 1	0.00Hz~P04.05	0.00Hz	□	F303
P04.04	Multi-point VF voltage 1	0.0%~100.0%	0.0%	□	F304
P04.05	Multi-point VF frequency 2	P04.03~P04.07	0.00Hz	□	F305
P04.06	Multi-point VF voltage 2	0.0%~100.0%	0.0%	□	F306
P04.07	Multi-point VF frequency 3	P04.05~Rated motor frequency (P02.04)	0.00Hz	□	F307
P04.08	Multi-point VF voltage 3	0.0%~100.0%	0.0%	□	F308
P04.09	VF slip compensation gain	0.0%~200.0%	100.0%	◇	F309
P04.10	VF over-excitation gain	0~200	64	◇	F30A
P04.11	VF oscillation		Model	◇	F30B

Chapter 6 Function Code Table

Function Code	LED/OLED Operation panel display	Setting range	Factory settings	Modify	Address
	suppressing gain	0~100	dependent		
P04.13	Voltage source for VF separation	0: Digital setting (P04.14) 1: AI1 2: AI2 3: AI3 4: Pulse setting(DI5) 5: Multi-reference 6: Simple PLC 7: PID 8: Communication setting Note: 100.0% corresponds to rated motor voltage	0	◇	F30D
P04.14	Voltage digital setting for VF separation	0V~Rated motor voltage	0V	◇	F30E
P04.15	Voltage rise time of VF separation	0.0s~1000.0s Note: It indicates that the time required for output voltage to rise from 0V to rated motor voltage	0.0s	◇	F30F
P04.16	VF separation voltage drop time	0.0s~1000.0s Note: It indicates that the time required for output voltage to rise from rated motor voltage to 0V	0.0s	◇	F310
P04.17	VF separation stop mode selection	0: frequency/voltage is independently reduced to 0 1: After the voltage is reduced to 0, the frequency begins to drop.	0.0s	◇	F311

Group P05: Input Terminals

Function Code	LED/OLED Operation panel display	Setting range	Factory settings	Modify	Address
P05.00	DI1 function selection	0: No function 1: Forward run(FWD)	1	□	F400
P05.01	DI2 function selection	2: Reverse run(REV) 3: Three-line control 4: Forward JOG(FJOG)	2	□	F401
P05.02	DI3 function selection	5: Reverse JOG(RJOG) 6: Terminal UP 7: Terminal DOWN	8	□	F402
P05.03	DI4 function selection	8: Coast to stop 9: Fault reset(RESET)	9	□	F403
P05.04	DI5 function selection	10: Run Pause(water-level anomaly on-off input) 11: Normally open input of external fault	12	□	F404
P05.05	DI6 function selection	12: Multi-reference terminal 1	13	□	F405

Chapter 6 Function code table

Function Code	LED/OLED Operation panel display	Setting range	Factory settings	Modify	Address
P05.06	DI7 function selection	13: Multi-reference terminal 2 14: Multi-reference terminal 3	0	<input type="checkbox"/>	F406
P05.07	DI8 function selection	15: Multi-reference terminal 4 16: Acceleration/Deceleration time selection terminal 1	0	<input type="checkbox"/>	F407
P05.08	Reserved	17: Acceleration/Deceleration time selection terminal 2	0	<input type="checkbox"/>	F408
P05.09	Reserved	18: Frequency source switchover 19: UP/DOWN setting clear (terminal\operation panel) 20: Command source switchover terminal 21: Acceleration/Deceleration prohibited 22: PID pause 23: PLC status reset 24: Swing pause 25: Counter input 26: Counter reset 27: Length count input 28: Length reset 29: Torque control prohibited 30: Pulse frequency input (only valid for DI5) 31: Reserved 32: Immediate DC braking 33: Normally closed input of external fault 34: Frequency modification enable 35: Reverse PID action direction 36: External stop terminal 1 37: Command source switchover terminal 2 38: PID integral pause 39: Switchover between main frequency source X and preset frequency 40: Switchover between main frequency source Y and preset frequency	—	<input type="checkbox"/>	F409
P05.09	Reserved	41: Motor selection terminal 1 42: Motor selection terminal 2 43: PID parameter switchover 44: User-defined fault 1 45: User-defined fault 2 46: speed control/ torque control Switchover 47: Emergency stop 48: External stop terminal 2 49: Deceleration DC braking 50: Clear the current running time 51: Forced to run the terminal when			

Chapter 6 Function Code Table

Function Code	LED/OLED Operation panel display	Setting range	Factory settings	Modify	Address
		below under voltage point 52: Deceleration stop function, but Jog effective 53-59: Reserved			
P05.10	DI filter time	0.000s~1.000s	0.010s	◇	F40A
P05.11	Terminal command mode	0: two-line mode 1 1: two-line mode 2 2: three-line mode 1 3: three-line mode 2	0	□	F40B
P05.12	Terminal UP/DOWN rate	0.001Hz/s~6 5.535Hz/s	1.00Hz/s	◇	F40C
P05.13	AI curve 1 minimum input	0.00V~P05.15	0.00V	◇	F40D
P05.14	Corresponding setting of AI curve 1 minimum input	-100.0%~+100.0%	0.0%	◇	F40E
P05.15	AI curve 1 maximum input	P05.13~+10.00V	10.00V	◇	F40F
P05.16	Corresponding setting of AI curve 1 maximum input	-100.0%~+100.0%	100.0%	◇	F410
P05.17	AI1 filter time	0.00s~10.00s	0.10s	◇	F411
P05.18	AI curve 2 minimum input	0.00V~P05.20	0.00V	◇	F412
P05.19	Corresponding setting of AI curve 2 minimum input	-100.0%~+100.0%	0.0%	◇	F413
P05.20	AI curve 2 maximum input	P05.18~+10.00V	10.00V	◇	F414
P05.21	Corresponding setting of AI curve 2 maximum input	-100.0%~+100.0%	100.0%	◇	F415
P05.22	AI2 filter time	0.00s~10.00s	0.10s	◇	F416
P05.23	AI curve 3 minimum input	-10.00V~P05.25	-10.00V	◇	F417
P05.24	Corresponding setting of AI curve 3 minimum input	-100.0%~+100.0%	-100.0%	◇	F418
P05.25	AI curve 3 maximum input	P05.23~+10.00V	10.00V	◇	F419

Chapter 6 Function code table

Function Code	LED/OLED Operation panel display	Setting range	Factory settings	Modify	Address
P05.26	Corresponding setting of AI curve 3 maximum input	-100.0%~+100.0%	100.0%	◇	F41A
P05.27	AI3 filter time	0.00s~10.00s	0.10s	◇	F41B
P05.28	PULSE minimum input	0.00kHz~P05.30	0.00KHz	◇	F41C
P05.29	Corresponding setting of pulse minimum input	-100.0%~100.0%	0.0%	◇	F41D
P05.30	PULSE maximum input	P05.28~100.00KHz	50.00KHz	◇	F41E
P05.31	Corresponding setting of pulse maximum input	-100.0%~100.0%	100.0%	◇	F41F
P05.32	PULSE filter time	0.00s~10.00s	0.10s	◇	F420
P05.33	AI curve selection	Unit's digit: AI1 curve selection 1: curve1(2points, see P05.13~P05.16) 2: curve2(2points, see P05.18~P05.21) 3: curve3(2points, see P05.23~P05.26) 4: curve4(4points, see P24.00~P24.07) 5: curve5(4points, see P24.08~P24.15) Ten's digit: AI2 curve selection, the same as AI1 Hundred's digit : AI3 curve selection, the same as AI1	321	◇	F421
P05.34	Setting for AI less than minimum input	Unit's digit: Setting for AI1 less than minimum input 0: Minimum value 1: 0.0% Ten's digit: Setting for AI2 less than minimum input, the same as AI1. Hundred's digit: Setting for AI3 less than minimum input, the same as AI1	000	◇	F422
P05.35	DI1 delay time	0.0s~3600.0s	0.0s	□	F423
P05.36	DI2 delay time	0.0s~3600.0s	0.0s	□	F424
P05.37	DI3 delay time	0.0s~3600.0s	0.0s	□	F425

Chapter 6 Function Code Table

Function Code	LED/OLED Operation panel display	Setting range	Factory settings	Modify	Address
P05.38	DI valid mode selection 1	0: High level valid 1: Low level valid Unit's digit: DI1 Ten's digit: DI2 Hundred's digit: DI3 Thousand's digit: DI4 Ten thousand's digit: DI5	00000	□	F426
P05.39	DI valid mode selection 2	0: High level valid 1: Low level valid Unit's digit: DI6 Ten's digit: DI7 Hundred's digit: DI8 Thousand's digit: Reserved Ten thousand's digit: Reserved	00000	□	F427

Group P06: Output Terminals

Function Code	LED/OLED Operation panel display	Setting range	Factory settings	Modify	Address
P06.00	SP terminal output mode	0: Pulse output(SPP) 1: Switch signal output(SPR)	0	◇	F500
P06.01	SPR function	0: No output 1: inverter running 2: Fault output(stop) 3: Frequency-lever detection FDT1 output 4: Frequency reached 5: Zero speed running(No output at stop) 6: Motor overload pre-warning 7: inverter overload pre-warning 8: Set count value reached 9: Designated count value reached 10: Length reached 11: PLC cycle complete 12: Accumulative running time reached 13: Frequency limited 14: Torque limited 15: Ready for run 16: AI1>AI2 17: Frequency upper limit reached 18: Frequency lower limit reached 19: Under-voltage state output 20: Communication setting 21: Reserved	0	◇	F501
P06.02	Relay function (TA1-TB1-TC1)		2	◇	F502
P06.03	Extension card relay function (TA2-TB2-TC2)		0	◇	F503
P06.04	SPA function selection		1	◇	F504
P06.05	Extension card SPB function selection		4	◇	F505

Chapter 6 Function code table

Function Code	LED/OLED Operation panel display	Setting range	Factory settings	Modify	Address
		22: Reserved 23: Zero-speed running(Having output at stop) 24: Accumulative power-on time reached 25: Frequency-lever detection FDT2 output 26: Frequency 1 reached 27: Frequency 2 reached 28: Current 1 reached 29: Current 2 reached 30: Timing reached 31: AI1 input exceeded 32: Load becoming 0 33: Reverse running 34: Zero current state 35: Module temperature reached 36: output current exceeded 37: Frequency lower limit reached(Having output at stop) 38: Alarm output(inverter continue to run) 39: Motor overheat pre-warning 40: Current running time reached 41: Fault output 42: Forward running 43: One inverter drives two motors 44: High pressure reached 45: Low pressure reached 46: Brake signal control output			
P06.06	SPP function selection	0: Running frequency	0	◇	F506
P06.07	AO1 function selection	1: Set frequency 2: Output current 3: Output torque 4: Output power	0	◇	F507
P06.08	Extension card AO2 function selection	5: Output voltage 6: Pulse input (100.% corresponds to 100.0KHz) 7: AI1 8: AI2 9: AI3(Extension card) 10: Length 11: Count value 12: Communication setting 13: Motor rotational speed 14: Output current(100.0% corresponds to 1000.0A) 15: Output voltage (100.0% corresponds to 1000.0V) 16: Reserved	1	◇	F508

Chapter 6 Function Code Table

Function Code	LED/OLED Operation panel display	Setting range	Factory settings	Modify	Address
P06.09	Maximum SPP output frequency	0.01KHz~100.00KHz	50.00KHz	◇	F509
P06.10	AO1 offset coefficient	-100.0%~+100.0%	0.0%	◇	F50A
P06.11	AO1 gain	-10.00~+10.00	1.00	◇	F50B
P06.12	Extension card AO2 offset coefficient	-100.0%~+100.0%	0.0%	◇	F50C
P06.13	Extension card AO2 gain	-10.00~+10.00	1.00	◇	F50D
P06.14	AO1 filter time	0.00s~10.00s	0.0s	◇	F50E
P06.15	AO2 filter time	0.00s~10.00s	0.0s	◇	F50F
P06.16	HDO filter time	0.00s~10.00s	0.0s	◇	F510
P06.17	SPR output relay time	0.0s~3600.0s	0.0s	◇	F511
P06.18	TA1-TB1-TC1output relay time	0.0s~3600.0s	0.0s	◇	F512
P06.19	TA2-TB2-TC2output relay time	0.0s~3600.0s	0.0s	◇	F513
P06.20	SPA output relay time	0.0s~3600.0s	0.0s	◇	F514
P06.21	SPB output relay time	0.0s~3600.0s	0.0s	◇	F515
P06.22	DO valid mode selection	0: Positive logic 1: Negative logic Unit's digit : SPR Ten's digit: TA1-TB1-TC1 Hundred digit: TA2-TB2-TC2 Thousand's digit: SPA Ten thousand's digit: SPB	00000	◇	F516

Group P07: Start/Stop Control

Function Code	LED/OLED Operation panel display	Setting range	Factory settings	Modify	Address
P07.00	Start mode	0: Direct start 1: Rotational speed tracking restart 2: Pre-excited start(Asynchronous motor)	0	◇	F600
P07.01	Rotational speed tracking	0: From frequency at stop 1: From zero speed 2: From maximum speed	0	□	F601
P07.02	Rotational speed tracking speed	1~100	20	◇	F602
P07.03	Start-up frequency	0.00Hz~10.00Hz	0.00Hz	◇	F603
P07.04	Start-up frequency holding time	0.0s~100.0s	0.0s	□	F604
P07.05	Start-up DC braking current /Pre-excited current	0%~100%	0%	□	F605
P07.06	Start-up DC braking time/Pre-excited time	0.0s~100.0s	0.0s	□	F606
P07.07	Acceleration/Deceleration time	0: Linear Acceleration/Deceleration 1: S-curve acceleration/deceleration A 2: S-curve acceleration/deceleration B	0	□	F607
P07.08	Time proportion of s-curve start segment	0.0%~(100.0%-P07.09)	30.0%	□	F608
P07.09	Time proportion of s-curve end segment	0.0%~(100.0%-P07.08)	30.0%	□	F609
P07.10	Stop mode	0: Deceleration to stop 1: Coast to stop	0	◇	F60A
P07.11	Initial frequency of DC braking to stop	0.00Hz~Maximum frequency	0.00Hz	◇	F60B
P07.12	Waiting time of DC braking to stop	0.0s~100.0s	0.0s	◇	F60C

Chapter 6 Function Code Table

Function Code	LED/OLED Operation panel display	Setting range	Factory settings	Modify	Address
P07.13	DC braking to stop current	0%~100%	0%	◇	F60D
P07.14	DC braking to stop time	0.0s~100.0s	0.0s	◇	F60E
P07.15	Brake using ratio	0%~100%	100%	◇	F60F

Group P08: Operation panel and display

Function Code	LED/OLED Operation panel display	Setting range	Factory settings	Modify	Address
P08.00	MF key function selection	0: MF key disabled 1: Switchover between operation panel and remote command control (terminal or communication) 2: Switchover between forward rotation and reverse rotation 3: Forward JOG 4: Reverse JOG	3	□	F700
P08.01	STOP/RESET key function	0: STOP/RESET key enable only in operation panel control 1: STOP/RESET key enable in any operation mode	1	◇	F701
P08.02	LED running parameter display 1	0000~FFFF Bit00: Running frequency(Hz) Bit01: Set frequency(Hz) Bit02: DC-BUS voltage(V) Bit03: Output voltage(V) Bit04: Output current(A) Bit05: Output power(KW) Bit06: Output torque(%) Bit07: DI input state Bit08: DO output state Bit09: AI1 voltage (V) Bit10: AI2 voltage (V) Bit11: AI3 voltage (V) Bit12: Count value Bit13: Length Bit14: Load speed display Bit15: PID setting	1F	◇	F702
P08.03	LED running parameter display2	0000~FFFF Bit00: PID Feedback Bit01: PLC Stage Bit02: Pulse setting frequency(kHz) Bit03: Running frequency 2(Hz) Bit04: Remaining running time Bit05: AI1 voltage before	0	◇	F703

Chapter 6 Function code table

Function Code	LED/OLED Operation panel display	Setting range	Factory settings	Modify	Address
		correction(V) Bit06: AI2 voltage before correction(V) Bit07: AI3 voltage before correction(V) Bit08: Linear speed Bit09: Current power-on time (Hour) Bit10: Current running time(Min) Bit11: Pulse setting frequency(Hz) Bit12: Communication setting value Bit13: Encoder feedback speed(Hz) Bit14: Main frequency X display(Hz) Bit15: Auxiliary frequency Y display(Hz)			
P08.04	LED stop parameter display	0000 ~ FFFF Bit00: Set frequency(Hz) Bit01: DC-BUS voltage(V) Bit02: DI input state Bit03: DO output state Bit04: AI1 voltage(V) Bit05: AI2 voltage(V) Bit06: AI3 voltage(V) Bit07: Count value Bit08: Length Bit09: PLC stage Bit10: Load speed Bit11: PID setting Bit12: Pulse setting frequency(kHz)	33	◇	F704
P08.05	Load speed display coefficient	0.0001 ~ 6.5000	1.0000	◇	F705
P08.06	Heatsink temperature of inverter module	0.0℃ ~ 100.0℃	-	■	F706
P08.07	Heatsink temperature of rectifier	0.0℃ ~ 100.0℃	-	■	F707
P08.08	Accumulative running time	0h ~ 65535h	-	■	F708
P08.09	Product number	PT300	-	■	F709
P08.10	Software version	-	-	■	F70A
P08.11	Number of decimal places for load speed display	0: 0 decimal place 1: 1 decimal place 2: 2 decimal place 3: 3 decimal place	1	◇	F70B
P08.12	Accumulative power-on time	0h ~ 65535h	-	■	F70C

Chapter 6 Function Code Table

Function Code	LED/OLED Operation panel display	Setting range	Factory settings	Modify	Address
P08.13	Accumulative power consumption	0~65535 KWH	-	■	F70D
P08.14	Operation panel encoder accuracy selection	0: 0.01Hz 1: 0.10Hz 2: 1.00Hz 3: 10.00Hz	0	□	F70E

Group P09: Auxiliary Functions

Function Code	LED/OLED Operation panel display	Setting range	Factory settings	Modify	Address
P09.00	JOG running frequency	0.00Hz~Maximum frequency	2.00Hz	◇	F800
P09.01	JOG acceleration time	0.0s~6500.0s	20.0s	◇	F801
P09.02	JOG deceleration time	0.0s~6500.0s	20.0s	◇	F802
P09.03	Acceleration 2	0.0s~6500.0s	Model dependent	◇	F803
P09.04	Deceleration 2	0.0s~6500.0s	Model dependent	◇	F804
P09.05	Acceleration 3	0.0s~6500.0s	Model dependent	◇	F805
P09.06	Deceleration 3	0.0s~6500.0s	Model dependent	◇	F806
P09.07	Acceleration 4	0.0s~6500.0s	Model dependent	◇	F807
P09.08	Deceleration 4	0.0s~6500.0s	Model dependent	◇	F808
P09.09	Jump frequency 1	0.00Hz~Maximum frequency	0.00Hz	◇	F809
P09.10	Jump frequency 2	0.00Hz~Maximum frequency	0.00Hz	◇	F80A
P09.11	Jump frequency amplitude	0.00Hz~Maximum frequency	0.00Hz	◇	F80B
P09.12	Forward/Reverse rotation dead-zone time	0.0s~3000.0s	0.0s	◇	F80C

Chapter 6 Function code table

Function Code	LED/OLED Operation panel display	Setting range	Factory settings	Modify	Address
P09.13	Reverse control	0: Enable 1: Disable	0	◇	F80D
P09.14	Running mode when set frequency lower than frequency lower limit	0: Run at frequency lower limit 1: Stop 2: Run at zero speed	0	◇	F80E
P09.15	Droop control	0.00Hz~10.00Hz	0.00Hz	◇	F80F
P09.16	Accumulative power-on time threshold	0h~65000h	0h	◇	F810
P09.17	Accumulative running time threshold	0h~65000h	0h	◇	F811
P09.18	Power-on terminal operation protection selection	0: The terminal running command is valid at power-on. 1: The terminal running command is invalid when the power is turned on.	1	◇	F812
P09.19	Frequency detection value (FDT1)	0.00Hz~Maximum frequency	50.00Hz	◇	F813
P09.20	Frequency detection hysteresis value (FDT1)	0.0%~100.0%(FDT1 level)	5.0%	◇	F814
P09.21	Detection range of frequency reached	0.0%~100.0%(Maximum frequency)	0.0%	◇	F815
P09.22	Jump frequency during acceleration/deceleration	0: Invalid 1: Valid	0	◇	F816
P09.25	Frequency switchover point between acceleration time 1 and acceleration time 2	0.00Hz~Maximum frequency	0.00Hz	◇	F819
P09.26	Frequency switchover point between deceleration time	0.00Hz~Maximum frequency	0.00Hz	◇	F81A

Chapter 6 Function Code Table

Function Code	LED/OLED Operation panel display	Setting range	Factory settings	Modify	Address
	1 and deceleration time 2				
P09.27	Terminal JOG preferred	0: Invalid 1: Valid	0	◇	F81B
P09.28	Frequency detection value (FDT2)	0.00Hz~Maximum frequency	50.00Hz	◇	F81C
P09.29	Frequency detection hysteresis value(FDT2)	0.0%~100.0%(FDT2 level)	5.0%	◇	F81D
P09.30	Any frequency detection value reaching 1	0.00Hz~Maximum frequency	50.00Hz	◇	F81E
P09.31	Any frequency detection amplitude reaching 1	0.0%~100.0%(Maximum frequency)	0.0%	◇	F81F
P09.32	Any frequency detection value reaching 2	0.00Hz~Maximum frequency	50.00Hz	◇	F820
P09.33	Any frequency detection amplitude reaching 2	0.0%~100.0%(Maximum frequency)	0.0%	◇	F821
P09.34	Zero-current detection level	0.0%~300.0% 100.0% correspond to rated motor current	5.0%	◇	F822
P09.35	Zero-current detection delay time	0.01s~600.00s	0.10s	◇	F823
P09.36	Output current threshold	0.0%(No detection) 0.1%~300.0%(Maximum frequency)	200.0%	◇	F824
P09.37	Output current threshold delay time	0.00s~600.00s	0.00s	◇	F825
P09.38	Any current reaching 1	0.0%~300.0%(Rated motor current)	100.0%	◇	F826
P09.39	Any current reaching 1 amplitude	0.0%~100.0%(Rated motor current)	0.0%	◇	F827

Chapter 6 Function code table

Function Code	LED/OLED Operation panel display	Setting range	Factory settings	Modify	Address
P09.40	Any current reaching 2	0.0%~300.0%(Rated motor current)	100.0%	◇	F828
P09.41	Any current reaching 2 amplitude	0.0%~100.0%(Rated motor current)	0.0%	◇	F829
P09.42	Timing function	0: Invalid 1: valid	0	◇	F82A
P09.43	Timing duration source	0: P09.44 setting 1: AI1 2: AI2 3: AI3 100% of analog input corresponds to the value of P09.44	0	◇	F82B
P09.44	Timing duration	0.0Min~6500.0Min	0.0Min	◇	F82C
P09.45	AI1 input voltage lower limit	0.00V~P09.46	3.10V	◇	F82D
P09.46	AI1 input voltage upper limit	P09.45~10.00V	6.80V	◇	F82E
P09.47	Module temperature threshold	0℃~100℃	75℃	◇	F82F
P09.48	Cooling fan control	0: Fan working during running 1: Fan working continuously	0	◇	F830
P09.49	Current running time reached	0.0Min~6500.0Min	0.0Min	◇	F831

Group P10: Fault and Protection

Function Code	LED/OLED Operation panel display	Setting range	Factory settings	Modify	Address
P10.00	Motor overload protection selection	0: Disable 1: Enable	1	◇	F900
P10.01	Motor overload protection gain	0.20~10.00	1.00	◇	F901
P10.02	Motor overload pre-warning coefficient	50%~100%	80%	◇	F902
P10.03	Over-voltage stall gain	0~100	30	◇	F903

Chapter 6 Function Code Table

Function Code	LED/OLED Operation panel display	Setting range	Factory settings	Modify	Address
P10.04	Over-voltage stall protective voltage	650V~800V	760V	◇	F904
P10.05	Over-current stall gain	0~100	20	◇	F905
P10.06	Over-current stall protective current	100%~200%	150%	◇	F906
P10.07	Short-circuit to ground upon power-on	0: Invalid 1: Valid	1	◇	F907
P10.08	Power default phase protection sensitivity	0-30.0%	13.0%	◇	F908
P10.09	Fault auto reset times	0~20	0	◇	F909
P10.10	DO action during fault auto reset	0: No action 1: Action	0	◇	F90A
P10.11	Time interval of fault auto reset	0.1s~100.0s	1.0s	◇	F90B
P10.12	Input phase loss protection selection	10: Disable 11: Enable	11	◇	F90C
P10.13	Output phase loss protection selection	0: Disable 1: Enable	1	◇	F90D
P10.14	First time fault type	0: No fault 1: Reserved 2: Acceleration over-current 3: Deceleration over-current 4: Constant speed over current 5: Acceleration over-voltage 6: Deceleration over-voltage 7: Constant speed over voltage 8: Buffer resistance overload 9: over voltage 10: Inverter overload 11: Motor overload 12: Input phase loss 13: Output phase loss 14: Module over-heat 15: External equipment fault 16: Communication abnormal 17: Contactor abnormal 18: Current detection abnormal 19: Motor auto-turning abnormal	—	■	F90E

Chapter 6 Function code table

Function Code	LED/OLED Operation panel display	Setting range	Factory settings	Modify	Address
		20: Encoder/PG card abnormal 21: Parameter R/W abnormal 22: Inverter hardware abnormal 23: Motor short-circuit to ground 24: Reserved 25: Reserved			
P10.15	Second time fault type		—	■	F90F
P10.16	Third time (latest) fault type	26: Accumulative running time reached 27: User-defined fault 1 28: User-defined fault 2 29: Accumulative power-on time reached 30: Load lost 31: PID feedback lost during running 40: Fast current restrict timeout 41: Motor switchover between running 42: Too large speed deviation 43: Motor over-speed 45: Motor over-heat 51: Initial position fault	—	■	F910
P10.17	Frequency upon third time (latest) fault	—	Hz	■	F911
P10.18	Current upon third time (latest) fault	—	A	■	F912
P10.19	DC-Bus voltage upon third time (latest) fault	—	V	■	F913
P10.20	Input terminal status upon third time (latest) fault	—	—	■	F914
P10.21	Output terminal status upon third time (latest) fault	—	—	■	F915
P10.22	inverter status upon third time (latest) fault	—	—	■	F916
P10.23	Power-on time upon third time (latest) fault	—	s	■	F917
P10.24	Running time	—	s	■	F918

Chapter 6 Function Code Table

Function Code	LED/OLED Operation panel display	Setting range	Factory settings	Modify	Address
	upon third time (latest) fault				
P10.27	Frequency upon second time (latest) fault	—	Hz	■	F91B
P10.28	Current upon second time (latest) fault	—	A	■	F91C
P10.29	DC-Bus voltage upon second time (latest) fault	—	V	■	F91D
P10.30	Input terminal status upon second time (latest) fault	—	—	■	F91E
P10.31	Output terminal status upon second time (latest) fault	—	—	■	F91F
P10.32	inverter status upon second time (latest) fault	—	—	■	F920
P10.33	Power-on time upon second time (latest) fault	—	s	■	F921
P10.34	Running time upon second time (latest) fault	—	s	■	F922
P10.37	Frequency upon first time (latest) fault	—	Hz	■	F925
P10.38	Current upon first time (latest) fault	—	A	■	F926
P10.39	DC-Bus voltage upon first time (latest) fault	—	V	■	F927
P10.40	Input terminal status upon first time (latest) fault	—	—	■	F928
P10.41	Output terminal status upon first time (latest) fault	—	—	■	F929

Chapter 6 Function code table

Function Code	LED/OLED Operation panel display	Setting range	Factory settings	Modify	Address
P10.42	inverter status upon first time (latest) fault	—	—	■	F92A
P10.43	Power-on time upon first time (latest) fault	—	s	■	F92B
P10.44	Running time upon first time (latest) fault	—	s	■	F92C
P10.47	Fault protection action selection 1	Unit's digit: Motor overload(11) 0: Coast to stop 1: Stop according to stop mode 2: Continue to run Ten's digit: Input phase loss(12) Hundred's digit: Output phase loss(13) Thousand's digit: External equipment fault(15) Ten thousand's digit: Communication abnormal (16)	00000	◇	F92F
P10.48	Fault protection action selection 2	Unit's digit: Encoder/PG card abnormal(20) 0: Coast to stop Ten's digit: Function code R/W abnormal(21) 0: Coast to stop 1: Stop according to stop mode Hundred's digit: Reserved Thousand's digit: Motor over-heat(25) Ten thousand's digit: Accumulative running time reached(26)	00000	◇	F930
P10.49	Fault protection action selection 3	Unit's digit: User-defined 1(27) 0: Coast to stop 1: Stop according to stop mode 2: Continue to run Ten's digit: User-defined 2(28) 0: Coast to stop 1: Stop according to stop mode 2: Continue to run Hundred's digit: Accumulative power-on time reached(29) 0: Coast to stop 1: Stop according to stop mode 2: Continue to run Thousand's digit: Load lost(30) 0: Coast to stop 1: Deceleration to stop 2: Decelerated to 7% of the rated	00000	◇	F931

Chapter 6 Function Code Table

Function Code	LED/OLED Operation panel display	Setting range	Factory settings	Modify	Address
		motor frequency and continues to run, when loading, automatically return to the set frequency running Ten thousand's digit: PID feedback lost during running(31) 0: Coast to stop 1: Stop according to stop mode 2: Continue to run			
P10.50	Fault protection action selection 4	Unit's digit: Too larger speed deviation(42) 0: Coast to stop 1: Stop according to stop mode 2: Continue to run Ten's digit: Motor over-speed(43) Hundred's digit: Initial position fault(51)	00000	◇	F932
P10.54	Frequency selection for continuing running upon fault	0: Current running frequency 1: Set frequency 2: Upper limit frequency 3: Lower limit frequency 4: Backup frequency upon abnormality	0	◇	F936
P10.55	Backup frequency upon abnormality	60.0%~100.0% (100.0%correspond to maximum frequency P01.10)	100.0%	◇	F937
P10.56	Motor temperature sensor type	0: No temperature sensor type 1: PT100 2: PT1000	0	◇	F938
P10.57	Motor overheat protection threshold	0℃~200℃	110℃	◇	F939
P10.58	Motor overheat warning threshold	0℃~200℃	90℃	◇	F93A
P10.59	Action selection at instantaneous power failure	0: Invalid 1: Deceleration 2: Deceleration to stop	0	◇	F93B
P10.60	Instantaneous stop non-stop frequency switching point	80.0%~100.0%	100.0%	◇	F93C
P10.61	Voltage rally judging time at instantaneous power failure	0.00s~100.00s	0.50s	◇	F93D

Chapter 6 Function code table

Function Code	LED/OLED Operation panel display	Setting range	Factory settings	Modify	Address
P10.62	Action judging voltage at instantaneous power failure	60.0%~100.0%(Standard bus voltage)	80.0%	◇	F93E
P10.63	protection of load lost	0: Invalid 1: Valid	0	◇	F93F
P10.64	Detection level of load lost	0.0~100.0%	10.0%	◇	F940
P10.65	Detection time of load lost	0.0~60.0s	1.0s	◇	F941
P10.66	Inverter overheat warning threshold setting	0.0℃~150.0℃	95℃	◇	F942
P10.67	Over-speed detection value	0.0%~50.0%(Maximum frequency)	20.0%	◇	F943
P10.68	Over-speed detection time	0.0s~60.0s	5.0s	◇	F944
P10.69	Detection value of speed deviation	0.0%~50.0%(Maximum frequency)	20.0%	◇	F945
P10.70	Detection time of speed deviation	0.0s~60.0s	0.0s	◇	F946

Group P11: PID Function

Function Code	LED/OLED Operation panel display	Setting range	Factory settings	Modify	Address
P11.00	PID setting source	0: P11.01 setting 1: AI1 2: AI2 3: AI3 4: Pulse setting(DI5) 5: Communication setting 6: Multi-reference setting 7: Keyboard Encoder setting	7	◇	FA00
P11.01	PID value setting	0~100.0bar(KG)	3.0bar	◇	FA01
P11.02	PID feedback source	0: AI1 1: AI2 2: AI3	0	◇	FA02

Chapter 6 Function Code Table

Function Code	LED/OLED Operation panel display	Setting range	Factory settings	Modify	Address
		3: AI1-AI2 4: Pulse setting(DI5) 5: Communication setting 6: AI1+AI2 7: MAX(AI1 , AI2) 8: MIN(AI1 , AI2)			
P11.03	PID action direction	0: Forward action 1: Reverse action	0	◇	FA03
P11.04	PID setting feedback range	0~100.0bar(KG)	10.0 bar	◇	FA04
P11.05	Proportion gain Kp1	0.0~100.0	20.0	◇	FA05
P11.06	Integral time Ti1	0.01s~10.00s	2.00s	◇	FA06
P11.07	Differential time Td1	0.000s~10.000s	0.000s	◇	FA07
P11.08	PID Cut-off frequency reverse rotation	0.00~Maximum frequency	0.00Hz	◇	FA08
P11.09	PID deviation limit	0.0%~100.0%	0.0%	◇	FA09
P11.10	PID differential limit	0.00%~100.00%	0.10%	◇	FA0A
P11.11	PID setting change time	0.00~650.00s	0.00s	◇	FA0B
P11.12	PID feedback filter time	0.00~60.00s	0.00s	◇	FA0C
P11.13	PID output filter time	0.00~60.00s	0.00s	◇	FA0D
P11.14	Percentage of sleep pressure deviation	0.0~5.0%	0.0%	◇	FA0E
P11.15	Proportion gain Kp2	0.0~100.0	20.0	◇	FA0F
P11.16	Integral time Ti2	0.01s~10.00s	1.00s	◇	FA10
P11.17	Differential time Td2	0.000s~10.000s	0.000s	◇	FA11
P11.18	PID parameter switchover condition	0: No switchover 1: Switchover via DI terminal 2: Automatic switchover based on deviation	0	◇	FA12

Chapter 6 Function code table

Function Code	LED/OLED Operation panel display	Setting range	Factory settings	Modify	Address
P11.19	PID parameter switchover deviation 1	0.0%~P11.20	20.0%	◇	FA13
P11.20	PID parameter switchover deviation 2	P11.19~100.0%	80.0%	◇	FA14
P11.21	PID initial value	0.0%~100.0%	0.0%	◇	FA15
P11.22	PID initial value holding time	0.00~650.00s	0.00s	◇	FA16
P11.23	Twice output bias, the Forward(FWD) is maximum value	0.00%~100.00%	1.00%	◇	FA17
P11.24	Twice output bias, the Reverse(REV) is maximum value	0.00%~100.00%	1.00%	◇	FA18
P11.25	PID integral property	Unit's digit: integral separated 0: Invalid 1: Valid Ten's digit: Whether to stop integral operation when the output reaches the limit 0: Continue integral operation 1: Stop integral operation	00	◇	FA19
P11.26	Detection value of PID feedback loss	0.0%: Not judging PID feedback loss 0.1%~100.0%	0.0%	◇	FA1A
P11.27	Detection time of PID feedback loss	0.0s~3600.0s	0.0s	◇	FA1B
P11.28	PID operation selection at stop	0: No operation at stop 1: Operation at stop	1	◇	FA1C
P11.29	Waking pressure	0~Sleeping pressure Bar(KG) (P11.04)	2.5 bar	◇	FA1D
P11.30	Waking delay time	0.0s~6500.0s	2.0s	◇	FA1E
P11.31	Sleeping pressure	0.0bar~Waking pressure	3.5 bar	◇	FA1F
P11.32	Sleeping delay time	0.0s~6500.0s	60.0s	◇	FA20

Chapter 6 Function Code Table

Group P12: Swing Frequency, Fixed Length and Count

Function Code	LED/OLED Operation panel display	Setting range	Factory settings	Modify	Address
P12.00	Swing frequency setting mode	0: Related to the central frequency 1: Related to the maximum frequency	0	◇	FB00
P12.01	Swing frequency amplitude	0.0%~100.0%	0.0%	◇	FB01
P12.02	Jump frequency amplitude	0.0%~50.0%	0.0%	◇	FB02
P12.03	Swing frequency cycle	0.1s~3000.0s	10.0s	◇	FB03
P12.04	Triangular wave rising time of swing frequency	0.1%~100.0%	50.0%	◇	FB04
P12.05	Setting length	0m~65535m	1000m	◇	FB05
P12.06	Actual length	0m~65535m	0m	◇	FB06
P12.07	Number of pulse per meter	0.1~6553.5	100.0	◇	FB07
P12.08	Set count value	1~65535	1000	◇	FB08
P12.09	Designated count value	1~65535	1000	◇	FB09

Group P13: Multi-Reference, Simple PLC

Function Code	LED/OLED Operation panel display	Setting range	Factory settings	Modify	Address
P13.00	Multi-reference 0	-100.0%~100.0%	0.0%	◇	FC00
P13.01	Multi-reference 1	-100.0%~100.0%	0.0%	◇	FC01
P13.02	Multi-reference 2	-100.0%~100.0%	0.0%	◇	FC02
P13.03	Multi-reference 3	-100.0%~100.0%	0.0%	◇	FC03
P13.04	Multi-reference 4	-100.0%~100.0%	0.0%	◇	FC04
P13.05	Multi-reference 5	-100.0%~100.0%	0.0%	◇	FC05
P13.06	Multi-reference 6	-100.0%~100.0%	0.0%	◇	FC06
P13.07	Multi-reference 7	-100.0%~100.0%	0.0%	◇	FC07
P13.08	Multi-reference 8	-100.0%~100.0%	0.0%	◇	FC08
P13.09	Multi-reference 9	-100.0%~100.0%	0.0%	◇	FC09
P13.10	Multi-reference 10	-100.0%~100.0%	0.0%	◇	FC0A

Chapter 6 Function code table

Function Code	LED/OLED Operation panel display	Setting range	Factory settings	Modify	Address
P13.11	Multi-reference 11	-100.0%~100.0%	0.0%	◇	FC0B
P13.12	Multi-reference 12	-100.0%~100.0%	0.0%	◇	FC0C
P13.13	Multi-reference 13	-100.0%~100.0%	0.0%	◇	FC0D
P13.14	Multi-reference 14	-100.0%~100.0%	0.0%	◇	FC0E
P13.15	Multi-reference 15	-100.0%~100.0%	0.0%	◇	FC0F
P13.16	Simple PLC running mode	0: Stop after inverter runs on cycle 1: Keep final values after inverter runs one cycle 2: Repeat after inverter runs one cycle	0	◇	FC10
P13.17	Simple PLC retentive selection upon power failure	Unit's digit: Retentive upon power failure 0: No 1: Yes Ten's digit: Retentive upon stop 0: No 1: Yes	00	◇	FC11
P13.18	Running time of simple PLC reference 0	0.0s(h) ~6500.0s(h)	0.0s(h)	◇	FC12
P13.19	Acceleration/Deceleration time of simple PLC reference 0	0~3	0	◇	FC13
P13.20	Running time of simple PLC reference 1	0.0s(h) ~6500.0s(h)	0.0s(h)	◇	FC14
P13.21	Acceleration/Deceleration time of simple PLC reference 1	0~3	0	◇	FC15
P13.22	Running time of simple PLC reference 2	0.0s(h) ~6500.0s(h)	0.0s(h)	◇	FC16
P13.23	Acceleration/Deceleration time of simple PLC reference 2	0~3	0	◇	FC17
P13.24	Running time of simple PLC reference 3	0.0s(h) ~6500.0s(h)	0.0s(h)	◇	FC18
P13.25	Acceleration/Deceleration time of simple PLC	0~3	0	◇	FC19

Chapter 6 Function Code Table

Function Code	LED/OLED Operation panel display	Setting range	Factory settings	Modify	Address
	reference 3				
P13.26	Running time of simple PLC reference 4	0.0s(h) ~6500.0s(h)	0.0s(h)	◇	FC1A
P13.27	Acceleration/Deceleration time of simple PLC reference 4	0~3	0	◇	FC1B
P13.28	Running time of simple PLC reference 5	0.0s(h) ~6500.0s(h)	0.0s(h)	◇	FC1C
P13.29	Acceleration/Deceleration time of simple PLC reference 5	0~3	0	◇	FC1D
P13.30	Running time of simple PLC reference 6	0.0s(h) ~6500.0s(h)	0.0s(h)	◇	FC1E
P13.31	Acceleration/Deceleration time of simple PLC reference 6	0~3	0	◇	FC1F
P13.32	Running time of simple PLC reference 7	0.0s(h) ~6500.0s(h)	0.0s(h)	◇	FC20
P13.33	Acceleration/Deceleration time of simple PLC reference 7	0~3	0	◇	FC21
P13.34	Running time of simple PLC reference 8	0.0s(h) ~6500.0s(h)	0.0s(h)	◇	FC22
P13.35	Acceleration/Deceleration time of simple PLC reference 8	0~3	0	◇	FC23
P13.36	Running time of simple PLC reference 9	0.0s(h) ~6500.0s(h)	0.0s(h)	◇	FC24
P13.37	Acceleration/Deceleration time of simple PLC reference 9	0~3	0	◇	FC25
P13.38	Running time of simple PLC reference 10	0.0s(h) ~6500.0s(h)	0.0s(h)	◇	FC26

Chapter 6 Function code table

Function Code	LED/OLED Operation panel display	Setting range	Factory settings	Modify	Address
P13.39	Acceleration/Deceleration time of simple PLC reference 10	0~3	0	◇	FC27
P13.40	Running time of simple PLC reference 11	0.0s(h) ~6500.0s(h)	0.0s(h)	◇	FC28
P13.41	Acceleration/Deceleration time of simple PLC reference 11	0~3	0	◇	FC29
P13.42	Running time of simple PLC reference 12	0.0s(h) ~6500.0s(h)	0.0s(h)	◇	FC2A
P13.43	Acceleration/Deceleration time of simple PLC reference 12	0~3	0	◇	FC2B
P13.44	Running time of simple PLC reference 13	0.0s(h) ~6500.0s(h)	0.0s(h)	◇	FC2C
P13.45	Acceleration/Deceleration time of simple PLC reference 13	0~3	0	◇	FC2D
P13.46	Running time of simple PLC reference 14	0.0s(h) ~6500.0s(h)	0.0s(h)	◇	FC2E
P13.47	Acceleration/Deceleration time of simple PLC reference 14	0~3	0	◇	FC2F
P13.48	Running time of simple PLC reference 15	0.0s(h) ~6500.0s(h)	0.0s(h)	◇	FC30
P13.49	Acceleration/Deceleration time of simple PLC reference 15	0~3	0	◇	FC31
P13.50	Time unit of simple PLC running	0: s(second) 1: h(hour)	0	◇	FC32
P13.51	Multi-reference 0 source	0: Set by P13.00 1: AI1 2: AI2	7	◇	FC33

Chapter 6 Function Code Table

Function Code	LED/OLED Operation panel display	Setting range	Factory settings	Modify	Address
		3: AI3 4: Pulse setting 5: PID 6: Set by preset frequency P01.08, modified via terminal UP/DOWN 7: Encoder potentiometer setting			

Group P14: Communication Parameters

Function Code	LED/OLED Operation panel display	Setting range	Factory settings	Modify	Address
P14.00	Baud rate	Unit's digit: MODBUS 0: 300BPS 1: 600BPS 2: 1200BPS 3: 2400BPS 4: 4800BPS 5: 9600BPS 6: 19200BPS 7: 38400BPS 8: 57600BPS 9: 115200BPS Ten's digit: Profibus-DP 0: 115200Bps 1: 208300Bps 2: 256000Bps 3: 512000Bps Hundred's digit: Reserved Ten thousand's digit: CANlink baud rate 0: 20 1: 50 2: 100 3: 125 4: 250 5: 500 6: 1M	6005	◇	FD00
P14.01	Data format	0: no parity (8-N-2) 1: even parity(8-E-1) 2: odd parity(8-O-1) 3: no parity(8-N-1)	0	◇	FD01
P14.02	Local address	1~247, 0 is broadcast address	1	◇	FD02
P14.03	Response delay	0ms~20ms	2	◇	FD03
P14.04	Communication timeout	0.0(invalid) , 0.1s~60.0s	0.0	◇	FD04
P14.05	Data transmission format selection	Unit's digit: MODBUS 0: Non-standard MODBUS protocol 1: Standard MODBUS protocol Ten's digit: Profibus-DP 0: PPO1 format 1: PPO2 format	31	◇	FD05

Chapter 6 Function code table

Function Code	LED/OLED Operation panel display	Setting range	Factory settings	Modify	Address
		2: PPO3 format 3: PPO5 format			
P14.06	Communication read current value resolution	0: 0.01A 1: 0.1A	0	◇	FD06
P14.07	Master-slave mode of communication	0: Slave communication 1: Master communication	0	◇	FD07

Group P15: Constant pressure water supply function parameters

Function Code	LED/OLED Operation panel display	Setting range	Factory settings	Modify	Address
P15.00	Simple macro debugging function	0: No function 1; One inverter drives two pumps water supply 2: Building water supply 3: Hotel water supply 4: Fire control water supply 5: Pressurized pump water supply 6: Deep water pump water supply	0	◇	FE00
P15.01	Pressure proportional linkage enable	0: Proportional linkage enable is OFF 1: Proportional linkage enable is ON	1	◇	FE01
P15.02	Wake up pressure linkage difference-value setting	0-100.0Bar(Kg)	0.5	◇	FE02
P15.03	Sleeping pressure linkage difference-value setting	0-100.0Bar(Kg)	0.5	◇	FE03
P15.04	High pressure value alarm	0.00~ Pressure-gauge's value Bar(Kg)	9.0	◇	FE04
P15.05	Low pressure value alarm	0.00~ Pressure-gauge's value Bar(Kg)	0.5	◇	FE05
P15.06	Water pressure abnormal alarm delay time	0-6553.5s overpressure fault alarm delay time	20.0	◇	FE06
P15.07	The water inlet Start Pressure	0~ Pressure-gauge's value Bar(Kg) BY P01.02 = 3 turn on water inlet start&stop control The water inlet must use the AI2 current sensor	3.0	◇	FE07
P15.08	The water inlet Stop Pressure	0~ Pressure-gauge's value Bar(Kg)	3.2	◇	FE08
P15.09	Number of auxiliary pumps	0-3	0	◇	FE09
P15.10	Auxiliary pump	0-1000.0s	60.0s	◇	FE0A

Chapter 6 Function Code Table

Function Code	LED/OLED Operation panel display	Setting range	Factory settings	Modify	Address
	start waiting time				
P15.11	Auxiliary pump On/Off waiting time	0-1000.0s	5.0s	◇	FE0B
P15.12	RO1 Function Relay ON frequency setting	0-50HZ When this value is reached, the relay outputs an ON signal	50.00	◇	FE0C
P15.13	RO1 Function Relay OFF frequency setting	0-50HZ When this value is reached, the relay outputs an OFF signal	30.00	◇	FE0D
P15.14	Water level control selection	0: Invalid 1: AI1 2: AI2 3: AI3 When 0 is selected, the water level control is invalid. 1 ~ 3 for the water level control analog signal source. when the analog signal source is selected, P15.15, P15.16, P15.17, P15.18 are valid	0	◇	FE0E
P15.15	Water level threshold	0.0 to 100.0% When the detected water level control analog signal is less than the water level threshold, and continues this state after the delay time of P15.16, report full water warning (A-tF), and sleep. If it is non-continuous, when the delay time does not reach, the given analog signal is greater than the water level threshold, the delay time will be automatically cleared as 0. And then in the measurement of water level control analog signal is less than the water level threshold, restart delay time.	25.0%	◇	FE0F
P15.16	Full water level delay	0 ~ 1000.0S full water delay time setting	6.0s	◇	FE10
P15.17	Empty water level delay	0 ~ 1000.0S Empty water delay time setting. In the full-water warning state, when the detected water level control analog signal is greater than the P15.15 water level threshold, Start delay time, this state continues after this parameter delay time, clear water warning, return to normal state. In case of non-continuation, the delay		◇	FE11

Chapter 6 Function code table

Function Code	LED/OLED Operation panel display	Setting range	Factory settings	Modify	Address
		time will be cleared as 0 automatically.			
P15.18	Damage point of hydraulic probe	0.0 ~ 100.0% 0.0% means invalid Non-0.0%, when the detected water level control analog signal is greater than P15.18 hydraulic probe damage point, the direct report (E. tSF) failure and shutdown	0.0%	◇	FE12
P15.19	Lack of water protection function	0: Off 1: On, in order to frequency&pressure for judge	0	◇	FE13
P15.20	Lack of water fault checking value	0~ Pressure-gauge's value Bar(Kg) When P15.19 = 1 valid When the feedback value is less than this value and go to judge whether the water shortage	0.5	◇	FE14
P15.21	Lack of water protection detect frequency	0-50.00HZ When P15.19 = 1 valid To determine whether the comparison frequency of water shortage, When the operating frequency is greater than or equal to this frequency, and water detection pressure is less than equal to P15.20, to determine water shortage.	50.00	◇	FE15
P15.22	Lack of water protection detect time	0-6553.5S Delay time of water shortage alarm	10	◇	FE16
P15.23	Check the pressure of incoming water	0~ Pressure-gauge's value Bar(Kg)	3.0	◇	FE17
P15.24	Check the time of incoming water	0~9999s	20.0s	◇	FE18
P15.25	Leakage Re - start deviation	0~ Pressure-gauge's value Bar(Kg)	0	◇	FE19
P15.26	Leakage re-start feedback value	0~ Pressure-gauge's value Bar(Kg)	0	◇	FE1A
P15.27	Leakage re-start feedback value detection time	0: No function 0.1-10.0 seconds	2.0s	◇	FE1B
P15.28	Sleeping mode	0: Sleeping, When the feedback pressure is greater than the sleep pressure, 1: Sleeping, When the operating frequency is less than the output frequency	0	◇	FE1C

Chapter 6 Function Code Table

Function Code	LED/OLED Operation panel display	Setting range	Factory settings	Modify	Address
		(Affected by P15.29) 2: Sleeping, When the feedback pressure is greater than the sleep pressure and the operating frequency is less than the sleep output frequency			
P15.29	Sleeping output frequency	0-P01.12	20.00Hz	◇	FE1D
P15.30	Reserved	Reserved	Reserved	◇	FE1E
P15.31	Reserved	Reserved	Reserved	◇	FE1F

Group P17: Function code management

Function Code	LED/OLED Operation panel display	Setting range	Factory settings	Modify	Address
P17.00	User password	0~65535	0	◇	1F00
P17.01	Parameter initialization	0: No operation 01: Recovery to factory settings, not including the motor parameters 02: Recovery to factory settings, including the motor parameters 03: Clear history informations 04: Recovery user backup parameters 501: Backup user's current parameters	0	◇	1F01
P17.02	Function parameter display selection	Unit's digit: P00 group display selection 0: No display 1: Display Ten's digit: P18-P30 group display selection 0: No display 1: Display	11	◇	1F02
P17.03	Personalized parameter group display selection	Unit's digit: User-customized parameter group display selection 0: No display 1: Display Ten's digit: User changes the parameter group display selection 0: No display 1: Display	00	◇	1F03
P17.04	Modify properties of the function code	0: Can be modified 1: Can not be modified	0	◇	1F04

Group P18: Torque Control Parameters

Function Code	LED/OLED Operation panel display	Setting range	Factory settings	Modify	Address
P18.00	Speed/Torque control mode selection	0: Speed control 1: Torque control	0	◇	A000
P18.01	Torque setting source in torque control mode	0: Digital setting 1(P18.03) 1: AI1 2: AI2 3: AI3 4: Pulse setting 5: Communication setting 6: MIN(AI1, AI2) 7: MAX(AI1, AI2) (Full range of 1-7 options correspond to P18.03 digital setting.)	0	◇	A001
P18.03	Torque digital setting in torque control mode	-200.0%~200.0%	150.0%	◇	A003
P18.04	Under the torque control mode, torque upper limit frequency setting source selection	0: Digital setting 1(P18.05 or P18.06) 1: AI1 2: AI2 3: AI3 4: Pulse setting 5: Communication setting 6: MIN(AI1, AI2) 7: MAX(AI1, AI2) (Full range of 1-7 options correspond to P18.05 digital setting.)	0	□	A004
P18.05	Forward maximum frequency in torque control	0.00Hz~Maximum frequency	50.00Hz	◇	A005
P18.06	Reverse maximum frequency in torque control	0.00Hz~Maximum frequency	50.00Hz	◇	A006
P18.07	Acceleration time in torque control	0.00s~650.00s	0.00s	◇	A007
P18.08	Deceleration time in torque control	0.00s~650.00s	0.00s	◇	A008

Group P19: Virtual DI/DO

Function Code	LED/OLED Operation panel display	Setting range	Factory settings	Modify	Address
P19.00	Virtual DI1 terminal function selection	0~59	0	◇	A100
P19.01	Virtual DI2 terminal function selection	0~59	0	◇	A101

Chapter 6 Function Code Table

Function Code	LED/OLED Operation panel display	Setting range	Factory settings	Modify	Address
P19.02	Virtual DI3 terminal function selection	0~59	0	◇	A102
P19.03	Virtual DI4 terminal function selection	0~59	0	◇	A103
P19.04	Virtual DI5 terminal function selection	0~59	0	◇	A104
P19.05	VDI state setting mode	0: Decided by state of VDOx 1: Decided by P19.06 Unit's digit: VDI1 Ten's digit: VDI2 Hundred's digit: VDI3 Thousand's digit: VDI4 Ten thousand's digit : VDI5	11111	◇	A105
P19.06	VDI state selection	0: Invalid 1: Valid Unit's digit: VDI1 Ten's digit: VDI2 Hundred's digit: VDI3 Thousand's digit: VDI4 Ten thousand's digit: VDI5	00000	◇	A106
P19.07	Function selection for AI1 used as DI	0~59	0	◇	A107
P19.08	Function selection for AI2 used as DI	0~59	0	◇	A108
P19.09	Function selection for AI3 used as DI	0~59	0	◇	A109
P19.10	Valid mode selection for AI used as DI	0: High-level valid 1: Low-level valid Unit's digit: AI1 Ten's digit: AI2 Hundred's digit: AI3	000	◇	A10A
P19.11	VDO1 function selection	0: Short with internal physical DIx 1-40: Refer to output function selection of physical SPA、SPB in group P06	0	◇	A10B
P19.12	VDO2 function selection	0: Short with internal physical DIx 1-40: Refer to output function selection of physical SPA、SPB in group P06.	0	◇	A10C
P19.13	VDO3 function selection	0: Short with internal physical DIx	0	◇	A10D

Chapter 6 Function code table

Function Code	LED/OLED Operation panel display	Setting range	Factory settings	Modify	Address
		1-40: Refer to output function selection of physical SPA、SPB in group P06			
P19.14	VDO4 function selection	0: Short with internal physical Dlx 1-40: Refer to output function selection of physical SPA、SPB in group P06	0	◇	A10E
P19.15	VDO5 function selection	0: Short with internal physical Dlx 1-40: Refer to output function selection of physical SPA、SPB in group P06.	0	◇	A10F
P19.16	VDO1 output delay time	0.0s~3600.0s	0.0s	◇	A110
P19.17	VDO2 output delay time	0.0s~3600.0s	0.0s	◇	A111
P19.18	VDO3 output delay time	0.0s~3600.0s	0.0s	◇	A112
P19.19	VDO4 output delay time	0.0s~3600.0s	0.0s	◇	A113
P19.20	VDO5 output delay time	0.0s~3600.0s	0.0s	◇	A114
P19.21	VDO state selection	0: Positive logic 1: Negative logic Unit's digit: VDO1 Ten's digit: VDO2 Hundred's digit: VDO3 Thousand's digit: VDO4 T Ten thousand's digit: VDO5	00000	◇	A115

Group P20: Motor 2 Parameters

Function Code	LED/OLED Operation panel display	Setting range	Factory settings	Modify	Address
P20.00	Motor type selection	0: common asynchronous motor 1: variable frequency asynchronous motor 2: permanent magnetic synchronous motor	0	◇	A200
P20.01	Rated motor power	0.1KW~1000.0KW	Model dependent	◇	A201
P20.02	Rated motor voltage	1V~2000V	Model dependent	◇	A202
P20.03	Rated motor current	0.01A~655.35A (inverter Power<=55KW)	Model dependent		

Chapter 6 Function Code Table

Function Code	LED/OLED Operation panel display	Setting range	Factory settings	Modify	Address
		0.1A~6553.5A (inverter Power>55KW)		◇	A203
P20.04	Rated motor frequency	0.01Hz~Maximum frequency	Model dependent	◇	A204
P20.05	Rated motor rotational speed	1rpm~65535rpm	Model dependent	◇	A205
P20.06	Stator resistance (asynchronous motor)	0.001Ω~65.535Ω (inverter Power<=55KW) 0.0001Ω~6.5535Ω (inverter Power>55KW)	Model dependent	◇	A206
P20.07	Rotor resistance (asynchronous motor)	0.001Ω~65.535Ω (inverter Power<=55KW) 0.0001Ω~6.5535Ω (inverter Power>55KW)	Model dependent	◇	A207
P20.08	leakage inductive Reactance (asynchronous motor)	0.01mH~655.35mH (inverter Power<=55KW) 0.001mH~65.535mH (inverter Power>55KW)	Model dependent	◇	A208
P20.09	mutual inductive Reactance (asynchronous motor)	0.01mH~655.35mH (inverter Power<=55KW) 0.001mH~65.535mH (inverter Power>55KW)	Model dependent	◇	A209
P20.10	No load current (asynchronous motor)	0.01A~P02.03 (inverter Power<=55KW) 0.1A~P02.03 (inverter Power>55KW)	Model dependent	◇	A20A
P20.16	stator resistance (synchronous motor)	0.001Ω~65.535Ω (inverter Power<=55KW) 0.0001Ω~6.5535Ω (inverter Power>55KW)	Model dependent	◇	A210
P20.17	shaft D inductance (synchronous motor)	0.01mH~655.35mH (inverter Power<=55KW) 0.001mH~65.535mH (inverter Power>55KW)	Model dependent	◇	A211
P20.18	shaft Q inductance (synchronous motor)	0.01mH~655.35mH (inverter Power<=55KW) 0.001mH~65.535mH (inverter Power>55KW)	Model dependent	◇	A212
P20.20	Back EMF (synchronous motor)	0.0V~6553.5V	Model dependent	◇	A214
P20.27	Encoder pulses per revolution	1~65535	2500	◇	A21B

Chapter 6 Function code table

Function Code	LED/OLED Operation panel display	Setting range	Factory settings	Modify	Address
P20.28	Encoder type	0: ABZ incremental encoder 1: UVW incremental encoder 2: Resolver 3: SIN/COS encoder 4: Wire-saving UVW encoder	0	◇	A21C
P20.29	Speed feedback PG selection	0: Local PG 1: Extend PG 2: PULSE input(DI5)	0	◇	A21D
P20.30	AB phase sequence of ABZ incremental encoder	0: Forward 1: Reverse	0	◇	A21E
P20.31	Encoder installation angle	0.0~359.9°	0.0°	◇	A21F
P20.32	UVW phase sequence of UVW encoder	0: Forward 1: Reverse	0	◇	A220
P20.33	UVW encoder angle offset	0.0~359.9°	0.0°	◇	A221
P20.34	Number of pole pairs of resolver	1~65535	1	◇	A222
P20.36	Encoder wire-break detection time	0.0: No action 0.1s~10.0s	0.0s	◇	A224
P20.37	Auto-turning selection	0: No auto-turning 1: Asynchronous motor static auto-turning 2: Asynchronous motor complete auto-turning 11: Synchronous motor static auto-turning 12: Synchronous motor complete auto-turning	0	◇	A225
P20.38	Speed loop proportional gain 1	1~100	30	◇	A226
P20.39	Speed loop integral time 1	0.01s~10.00s	0.50s	◇	A227
P20.40	Switchover frequency 1	0.00~P20.43	5.00Hz	◇	A228
P20.41	Speed loop proportional gain 2	1~100	20	◇	A229

Chapter 6 Function Code Table

Function Code	LED/OLED Operation panel display	Setting range	Factory settings	Modify	Address
P20.42	Speed loop integral time 2	0.01s~10.00s	1.00s	◇	A22A
P20.43	Switchover frequency 2	P20.40~Maximum frequency	10.00Hz	◇	A22B
P20.44	Vector control slip gain	50%~200%	100%	◇	A22C
P20.45	Time constant of speed loop filter	0.000s~0.100s	0.000s	◇	A22D
P20.46	Vector control over-excitation gain	0~200	64	◇	A22E
P20.47	Torque upper limit source in speed control mode	0: Set by function code P20.48 1: AI1 2: AI2 3: AI3 4: Pulse setting 5: Communication setting 6: MIN(AI1, AI2) 7: MAX(AI1, AI2) The full range of 1-7 options correspond to P20.48	0	◇	A22F
P20.48	Digital setting of torque upper limit in speed control mode	0.0%~200.0%	150.0%	◇	A230
P20.51	Excitation adjustment proportion gain	0~60000	2000	◇	A233
P20.52	Excitation adjustment integral gain	0~60000	1300	◇	A234
P20.53	Torque adjustment proportion gain	0~60000	2000	◇	A235
P20.54	Torque adjustment integral gain	0~60000	1300	◇	A236
P20.55	Speed loop integral property	Unit's digit: Integral separation 0: Invalid 1: Valid	0	◇	A237
P20.56	Field weakening mode of synchronous motor	0: No field weakening 1: Direct calculation 2: Automatic adjustment	1	◇	A238

Function Code	LED/OLED Operation panel display	Setting range	Factory settings	Modify	Address
P20.57	Field weakening depth of synchronous motor	50%~500%	100%	◇	A239
P20.58	Maximum field weakening current	1%~300%	50%	◇	A23A
P20.59	Field weakening automatic adjustment gain	10%~500%	100%	◇	A23B
P20.60	Field weakening integral multiple	2~10	0	◇	A23C
P20.61	Motor 2 control mode	0: Sensorless Vector Control (SVC) 1: Closed-Loop Vector Control(FVC) 2: Voltage/Frequency Control	0	◇	A23D
P20.62	Motor 2 acceleration/deceleration time selection	0: Same as motor 1 1: Acceleration/Deceleration time 1 2: Acceleration/Deceleration time 2 3: Acceleration/Deceleration time 3 4: Acceleration/Deceleration time 4	0	◇	A23E
P20.63	Motor 2 torque boost	0.0%: Automatic torque boost 0.1%~30.0%	Model dependent	◇	A23F
P20.65	Motor 2 oscillation suppressing	0~100	Model dependent	◇	A241

Group P21: Motor 3 Parameters

Function Code	LED/OLED Operation panel display	Setting range	Factory settings	Modify	Address
P21.00	Motor type selection	0: common asynchronous motor 1: variable frequency asynchronous motor 2: permanent magnetic synchronous motor	0	◇	A200
P21.01	Rated motor power	0.1KW~1000.0KW	Model dependent	◇	A201
P21.02	Rated motor voltage	1V~2000V	Model dependent	◇	A202
P21.03	Rated motor current	0.01A~655.35A (inverter Power<=55KW) 0.1A~6553.5A (inverter Power>55KW)	Model dependent	◇	A203

Chapter 6 Function Code Table

Function Code	LED/OLED Operation panel display	Setting range	Factory settings	Modify	Address
P21.04	Rated motor frequency	0.01Hz~ Maximum frequency	Model dependent	◇	A204
P21.05	Rated motor rotational speed	1rpm~65535rpm	Model dependent	◇	A205
P21.06	Stator resistance (asynchronous motor)	0.001Ω~65.535Ω (inverter Power≤55KW) 0.0001Ω~6.5535Ω (inverter Power>55KW)	Model dependent	◇	A206
P21.07	Rotor resistance (asynchronous motor)	0.001Ω~65.535Ω (inverter Power≤55KW) 0.0001Ω~6.5535Ω (inverter Power>55KW)	Model dependent	◇	A207
P21.08	leakage inductive Reactance (asynchronous motor)	0.01mH~655.35mH (inverter Power≤55KW) 0.001mH~65.535mH (inverter Power>55KW)	Model dependent	◇	A208
P21.09	mutual inductive Reactance (asynchronous motor)	0.01mH~655.35mH (inverter Power≤55KW) 0.001mH~65.535mH (inverter Power>55KW)	Model dependent	◇	A209
P21.10	No load current (asynchronous motor)	0.01A~P02.03 (inverter Power≤55KW) 0.1A~P02.03 (inverter Power>55KW)	Model dependent	◇	A20A
P21.16	stator resistance (synchronous motor)	0.001Ω~65.535Ω (inverter Power≤55KW) 0.0001Ω~6.5535Ω (inverter Power>55KW)	Model dependent	◇	A210
P21.17	shaft D inductance (synchronous motor)	0.01mH~655.35mH (inverter Power≤55KW) 0.001mH~65.535mH (inverter Power>55KW)	Model dependent	◇	A211
P21.18	shaft Q inductance (synchronous motor)	0.01mH~655.35mH (inverter Power≤55KW) 0.001mH~65.535mH (inverter Power>55KW)	Model dependent	◇	A212
P21.20	Back EMF (synchronous motor)	0.0V~6553.5V	Model dependent	◇	A214
P21.27	Encoder pulses per revolution	1~65535	2500	◇	A21B

Chapter 6 Function code table

Function Code	LED/OLED Operation panel display	Setting range	Factory settings	Modify	Address
P21.28	Encoder type	0: ABZ incremental encoder 1: UVW incremental encoder 2: Resolver 3: SIN/COS encoder 4: Wire-saving UVW encoder	0	◇	A21C
P21.29	Speed feedback PG selection	0: Local PG 1: Extend PG 2: PULSE input(DI5)	0	◇	A21D
P21.30	AB phase sequence of ABZ incremental encoder	0: Forward 1: Reverse	0	◇	A21E
P21.31	Encoder installation angle	0.0~359.9°	0.0°	◇	A21F
P21.32	UVW phase sequence of UVW encoder	0: Forward 1: Reverse	0	◇	A220
P21.33	UVW encoder angle offset	0.0~359.9°	0.0°	◇	A221
P21.34	Number of pole pairs of resolver	1~65535	1	◇	A222
P21.36	Encoder wire-break detection time	0.0: No action 0.1s~10.0s	0.0s	◇	A224
P21.37	Auto-turning selection	0: No auto-turning 1: Asynchronous motor static auto-turning 2: Asynchronous motor complete auto-turning 11: Synchronous motor static auto-turning 12: Synchronous motor complete auto-turning	0	◇	A225
P21.38	Speed loop proportional gain 1	1~100	30	◇	A226
P21.39	Speed loop integral time 1	0.01s~10.00s	0.50s	◇	A227
P21.40	Switchover frequency 1	0.00~P21.43	5.00Hz	◇	A228
P21.41	Speed loop proportional gain 2	1~100	20	◇	A229

Chapter 6 Function Code Table

Function Code	LED/OLED Operation panel display	Setting range	Factory settings	Modify	Address
P21.42	Speed loop integral time 2	0.01s~10.00s	1.00s	◇	A22A
P21.43	Switchover frequency 2	P21.40~Maximum frequency	10.00Hz	◇	A22B
P21.44	Vector control slip gain	50%~200%	100%	◇	A22C
P21.45	Time constant of speed loop filter	0.000s~0.100s	0.000s	◇	A22D
P21.46	Vector control over-excitation gain	0~200	64	◇	A22E
P21.47	Torque upper limit source in speed control mode	0: Set by function code P20.48 1: AI1 2: AI2 3: AI3 4: Pulse setting 5: Communication setting 6: MIN(AI1, AI2) 7: MAX(AI1, AI2) The full range of 1-7 options correspond to P21.48	0	◇	A22F
P21.48	Digital setting of torque upper limit in speed control mode	0.0%~200.0%	150.0%	◇	A230
P21.51	Excitation adjustment proportion gain	0~60000	2000	◇	A233
P21.52	Excitation adjustment integral gain	0~60000	1300	◇	A234
P21.53	Torque adjustment proportion gain	0~60000	2000	◇	A235
P21.54	Torque adjustment integral gain	0~60000	1300	◇	A236
P21.55	Speed loop integral property	Unit's digit: Integral separation 0: Invalid 1: Valid	0	◇	A237
P21.56	Field weakening mode of synchronous motor	0: No field weakening 1: Direct calculation 2: Automatic adjustment	1	◇	A238

Chapter 6 Function code table

Function Code	LED/OLED Operation panel display	Setting range	Factory settings	Modify	Address
P21.57	Field weakening depth of synchronous motor	50%~500%	100%	◇	A239
P21.58	Maximum field weakening current	1%~300%	50%	◇	A23A
P21.59	Field weakening automatic adjustment gain	10%~500%	100%	◇	A23B
P21.60	Field weakening integral multiple	2~10	0	◇	A23C
P21.61	Motor 3 control mode	0: Sensorless Vector Control (SVC) 1: Closed-Loop Vector Control(FVC) 2: Voltage/Frequency Control	0	◇	A23D
P21.62	Motor 3 acceleration/deceleration time selection	0: Same as motor 1 1: Acceleration/Deceleration time 1 2: Acceleration/Deceleration time 2 3: Acceleration/Deceleration time 3 4: Acceleration/Deceleration time 4	0	◇	A23E
P21.63	Motor 3 torque boost	0.0%: Automatic torque boost 0.1%~30.0%	Model dependent	◇	A23F
P21.65	Motor 3 oscillation suppressing	0~100	Model dependent	◇	A241

Group P22: Motor 4 Parameters

Function Code	LED/OLED Operation panel display	Setting range	Factory settings	Modify	Address
P22.00	Motor type selection	0: common asynchronous motor 1: variable frequency asynchronous motor 2: permanent magnetic synchronous motor	0	◇	A200
P22.01	Rated motor power	0.1KW~1000.0KW	Model dependent	◇	A201
P22.02	Rated motor voltage	1V~2000V	Model dependent	◇	A202
P22.03	Rated motor current	0.01A~655.35A (inverter Power<=55KW) 0.1A~6553.5A (inverter Power>55KW)	Model dependent	◇	A203

Chapter 6 Function Code Table

Function Code	LED/OLED Operation panel display	Setting range	Factory settings	Modify	Address
P22.04	Rated motor frequency	0.01Hz~ Maximum frequency	Model dependent	◇	A204
P22.05	Rated motor rotational speed	1rpm~65535rpm	Model dependent	◇	A205
P22.06	Stator resistance (asynchronous motor)	0.001Ω~65.535Ω (inverter Power≤55KW) 0.0001Ω~6.5535Ω (inverter Power>55KW)	Model dependent	◇	A206
P22.07	Rotor resistance (asynchronous motor)	0.001Ω~65.535Ω (inverter Power≤55KW) 0.0001Ω~6.5535Ω (inverter Power>55KW)	Model dependent	◇	A207
P22.08	leakage inductive Reactance (asynchronous motor)	0.01mH~655.35mH (inverter Power≤55KW) 0.001mH~65.535mH (inverter Power>55KW)	Model dependent	◇	A208
P22.09	mutual inductive Reactance (asynchronous motor)	0.01mH~655.35mH (inverter Power≤55KW) 0.001mH~65.535mH (inverter Power>55KW)	Model dependent	◇	A209
P22.10	No load current (asynchronous motor)	0.01A~P02.03 (inverter Power≤55KW) 0.1A~P02.03 (inverter Power>55KW)	Model dependent	◇	A20A
P22.16	stator resistance (synchronous motor)	0.001Ω~65.535Ω (inverter Power≤55KW) 0.0001Ω~6.5535Ω (inverter Power>55KW)	Model dependent	◇	A210
P22.17	shaft D inductance (synchronous motor)	0.01mH~655.35mH (inverter Power≤55KW) 0.001mH~65.535mH (inverter Power>55KW)	Model dependent	◇	A211
P22.18	shaft Q inductance (synchronous motor)	0.01mH~655.35mH (inverter Power≤55KW) 0.001mH~65.535mH (inverter Power>55KW)	Model dependent	◇	A212
P22.20	Back EMF (synchronous motor)	0.0V~6553.5V	Model dependent	◇	A214
P22.27	Encoder pulses per revolution	1~65535	2500	◇	A21B

Function Code	LED/OLED Operation panel display	Setting range	Factory settings	Modify	Address
P22.28	Encoder type	0: ABZ incremental encoder 1: UVW incremental encoder 2: Resolver 3: SIN/COS encoder 4: Wire-saving UVW encoder	0	◇	A21C
P22.29	Speed feedback PG selection	0: Local PG 1: Extended PG 2: PULSE input(D15)	0	◇	A21D
P22.30	AB phase sequence of ABZ incremental encoder	0: Forward 1: Reverse	0	◇	A21E
P22.31	Encoder installation angle	0.0~359.9°	0.0°	◇	A21F
P22.32	UVW phase sequence of UVW encoder	0: Forward 1: Reverse	0	◇	A220
P22.33	UVW encoder angle offset	0.0~359.9°	0.0°	◇	A221
P22.34	Number of pole pairs of resolver	1~65535	1	◇	A222
P22.36	Encoder wire-break detection time	0.0: No action 0.1s~10.0s	0.0s	◇	A224
P22.37	Auto-turning selection	0: No auto-turning 1: Asynchronous motor static auto-turning 2: Asynchronous motor complete auto-turning 11: Synchronous motor static auto-turning 12: Synchronous motor complete auto-turning	0	◇	A225
P22.38	Speed loop proportional gain 1	1~100	30	◇	A226
P22.39	Speed loop integral time 1	0.01s~10.00s	0.50s	◇	A227
P22.40	Switchover frequency 1	0.00~P22.43	5.00Hz	◇	A228
P22.41	Speed loop proportional gain 2	1~100	20	◇	A229

Chapter 6 Function Code Table

Function Code	LED/OLED Operation panel display	Setting range	Factory settings	Modify	Address
P22.42	Speed loop integral time 2	0.01s~10.00s	1.00s	◇	A22A
P22.43	Switchover frequency 2	P22.40~Maximum frequency	10.00Hz	◇	A22B
P22.44	Vector control slip gain	50%~200%	100%	◇	A22C
P22.45	Time constant of speed loop filter	0.000s~0.100s	0.000s	◇	A22D
P22.46	Vector control over-excitation gain	0~200	64	◇	A22E
P22.47	Torque upper limit source in speed control mode	0: Set by function code P20.48 1: AI1 2: AI2 3: AI3 4: Pulse setting 5: Communication setting 6: MIN(AI1, AI2) 7: MAX(AI1, AI2) The full range of 1-7 options correspond to P22.48	0	◇	A22F
P22.48	Digital setting of torque upper limit in speed control mode	0.0%~200.0%	150.0%	◇	A230
P22.51	Excitation adjustment proportion gain	0~60000	2000	◇	A233
P22.52	Excitation adjustment integral gain	0~60000	1300	◇	A234
P22.53	Torque adjustment proportion gain	0~60000	2000	◇	A235
P22.54	Torque adjustment integral gain	0~60000	1300	◇	A236
P22.55	Speed loop integral property	Unit's digit: Integral separation 0: Invalid 1: Valid	0	◇	A237
P22.56	Field weakening mode of synchronous motor	0: No field weakening 1: Direct calculation 2: Automatic adjustment	1	◇	A238

Function Code	LED/OLED Operation panel display	Setting range	Factory settings	Modify	Address
P22.57	Field weakening depth of synchronous motor	50%~500%	100%	◇	A239
P22.58	Maximum field weakening current	1%~300%	50%	◇	A23A
P22.59	Field weakening automatic adjustment gain	10%~500%	100%	◇	A23B
P22.60	Field weakening integral multiple	2~10	0	◇	A23C
P22.61	Motor 3 control mode	0: Sensorless Vector Control (SVC) 1: Closed-Loop Vector Control(FVC) 2: Voltage/Frequency Control	0	◇	A23D
P22.62	Motor 3 acceleration/deceleration time selection	0: Same as motor 1 1: Acceleration/Deceleration time 1 2: Acceleration/Deceleration time 2 3: Acceleration/Deceleration time 3 4: Acceleration/Deceleration time 4	0	◇	A23E
P22.63	Motor 3 torque boost	0.0%: Automatic torque boost 0.1%~30.0%	Model dependent	◇	A23F
P22.65	Motor 3 oscillation suppressing	0~100	Model dependent	◇	A241

Group P23: Control Optimization Parameters

Function Code	LED/OLED Operation panel display	Setting range	Factory settings	Modify	Address
P23.00	DPWM switchover upper limit frequency	0.00Hz~15.00Hz	12.00Hz	◇	A500
P23.01	PWM modulation mode	0: Asynchronous modulation 1: Synchronous modulation	0	◇	A501
P23.02	Dead-zone compensation mode selection	0: No compensation 1: Compensation mode 1 2: Compensation mode 2	1	◇	A502
P23.03	Random PWM depth	0: Random PWM invalid 1~10: PWM carrier frequency random depth	0	◇	A503
P23.04	Rapid current limit	0: Disabled 1: Enabled	1	◇	A504
P23.05	Current detection	0~100	5	◇	A505

Chapter 6 Function Code Table

Function Code	LED/OLED Operation panel display	Setting range	Factory settings	Modify	Address
	compensation				
P23.06	Under-voltage point setting	220V type: 180.0v 380V type: 350.0v 480V type: 350.0v 690V type: 650.0v	350.0V	◇	A506
P23.07	SVC optimization mode selection	0: No optimization 1: Optimization mode 1 2: Optimization mode 2	1	◇	A507
P23.08	Dead-zone time adjustment	100%~200%	150%	◇	A508
P23.09	Overvoltage threshold	220V type: 400.0v 380V type: 800.0v 480V type: 890.0v 690V type: 1300.0v	800.0V	◇	A509
P23.10	Low-frequency variable carrier on/off	0: Low-frequency carrier on/off close 1: Low frequency carrier on/off open	1	◇	A50A
P23.11	Zero speed running output control enabled	0: Invalid 1: Enabled	1	◇	A50B
P23.12	Braking unit operating starting voltage	650V~800V	690V	◇	A50C

Group P24: AI Curve Setting

Function Code	LED/OLED Operation panel display	Setting range	Factory settings	Modify	Address
P24.00	AI curve 4 minimum input	-10.00V~P24.02	0.00V	◇	A600
P24.01	Corresponding setting of AI curve 4 minimum input	-100.0%~+100.0%	0.0%	◇	A601
P24.02	AI curve 4 inflection 1 input	P24.00~P24.04	3.00V	◇	A602
P24.03	Corresponding setting of AI curve 4 inflection 1 input	-100.0%~+100.0%	30.0%	◇	A603
P24.04	AI curve 4 inflection 2 input	P24.02~P24.06	6.00V	◇	A604
P24.05	Corresponding setting of AI curve	-100.0%~+100.0%	60.0%	◇	A605

Chapter 6 Function code table

Function Code	LED/OLED Operation panel display	Setting range	Factory settings	Modify	Address
	4 inflection 2 input				
P24.06	AI curve 4 maximum input	P24.06~+10.00V	10.00V	◇	A606
P24.07	Corresponding setting of AI curve 4 maximum input	-100.0%~+100.0%	100.0%	◇	A607
P24.08	AI curve 5 minimum input	-10.00V~P24.10	-10.00V	◇	A608
P24.09	Corresponding setting of AI curve 5 minimum input	-100.0%~+100.0%	-100.0%	◇	A609
P24.10	AI curve 5 inflection 1 input	P24.08~P24.12	-3.00V	◇	A60A
P24.11	Corresponding setting of AI curve 5 inflection 1 input	-100.0%~+100.0%	-30.0%	◇	A60B
P24.12	AI curve 5 inflection 2 input	P24.10~P24.14	3.00V	◇	A60C
P24.13	Corresponding setting of AI curve 5 inflection 2 input	-100.0%~+100.0%	30.0%	◇	A60D
P24.14	AI curve 5 maximum input	P24.12~+10.00V	10.00V	◇	A60E
P24.15	Corresponding setting of AI curve 5 maximum input	-100.0%~+100.0%	100.0%	◇	A60F
P24.24	Jump point of AI1 input according setting	-100.0%~100.0%	0.0%	◇	A618
P24.25	Jump amplitude of AI1 input according setting	0.0%~100.0%	0.5%	◇	A619
P24.26	Jump point of AI2 input according setting	-100.0%~100.0%	0.0%	◇	A61A
P24.27	Jump amplitude of AI2 input according setting	0.0%~100.0%	0.5%	◇	A61B

Chapter 6 Function Code Table

Function Code	LED/OLED Operation panel display	Setting range	Factory settings	Modify	Address
P24.28	Jump point of AI3 input according setting	-100.0%~100.0%	0.0%	◇	A61C
P24.29	Jump amplitude of AI3 input according setting	0.0%~100.0%	0.5%	◇	A61D

Group P26: Master-slave control parameters

Function Code	LED/OLED Operation panel display	Setting range	Factory settings	Modify	Address
P26.00	Peer-to-peer communication function selection	0: Invalid 1: Valid	0	◇	A800
P26.01	Master-slave selection	0: Slave control 1: Master control	0	◇	A801
P26.02	The master sends data	0: Output torque 1: Operating frequency 2: Setting frequency 3: Feedback speed	0	◇	A802
P26.03	The slave receives data	0: Torque reference 1: frequency reference	0	◇	A803
P26.04	Receiving data offset	-100.0%~100.0%	0	◇	A804
P26.05	Receive data gain	-100.0%~100.0%	10.0%	◇	A805
P26.06	Peer-to-peer communication interrupt detection time	0.0s~10.0s	0s	◇	A806
P26.07	Peer-to-peer communication Master's data transmission cycle	0.0s~20.0s	10.0s	◇	A807

Group P27: Brake function parameters

Function Code	LED/OLED Operation panel display	Setting range	Factory settings	Modify	Address
P27.00	Brake control enable selection	0~1	0	◇	A900
P27.01	Brake-release frequency	0.00Hz~20.00Hz	2.50Hz	◇	A901
P27.02	Brake-release frequency maintain time	0.0s~20.0s	1.0s	◇	A902
P27.03	Current limit value during Braking	50.0%~200.0%	120.0%	◇	A903
P27.04	Brake frequency	-0.00Hz~20.00Hz	1.50Hz	◇	A904
P27.05	The time of the brake delay time	0.0s~20.0s	0.0s	◇	A905
P27.06	Brake frequency maintain time	0.0s~20.0s	1.0s	◇	A906

Group P30: AIAO Correction

Function Code	LED/OLED Operation panel display	Setting range	Factory settings	Modify	Address
P30.00	A11 measured voltage 1	0.500V~4.000V	Factory-corrected	◇	AC00
P30.01	A11 displayed voltage 1	0.500V~4.000V	Factory-corrected	◇	AC01
P30.02	A11 measured voltage 2	6.000V~9.999V	Factory-corrected	◇	AC02
P30.03	A11 displayed voltage 2	6.000V~9.999V	Factory-corrected	◇	AC03
P30.04	A12 measured voltage 1	0.500V~4.000V	Factory-corrected	◇	AC04
P30.05	A12 displayed voltage 1	0.500V~4.000V	Factory-corrected	◇	AC05
P30.06	A12 measured voltage 2	6.000V~9.999V	Factory-corrected	◇	AC06
P30.07	A12 displayed voltage 2	6.000V~9.999V	Factory-corrected	◇	AC07
P30.08	A13 measured voltage 1	-9.999V~10.000V	Factory-corrected	◇	AC08

Chapter 6 Function Code Table

Function Code	LED/OLED Operation panel display	Setting range	Factory settings	Modify	Address
P30.09	AI3 displayed voltage 1	-9.999V~10.000V	Factory-corrected	◇	AC09
P30.10	AI3 measured voltage 2	-9.999V~10.000V	Factory-corrected	◇	AC0A
P30.11	AI3 displayed voltage 2	-9.999V~10.000V	Factory-corrected	◇	AC0B
P30.12	AO1 targeted voltage 1	0.500V~4.000V	Factory-corrected	◇	AC0C
P30.13	AO1 measured voltage 1	0.500V~4.000V	Factory-corrected	◇	AC0D
P30.14	AO1 targeted voltage 2	6.000V~9.999V	Factory-corrected	◇	AC0E
P30.15	AO1 measured voltage 2	6.000V~9.999V	Factory-corrected	◇	AC0F
P30.16	AO2 targeted voltage 1	0.500V~4.000V	Factory-corrected	◇	AC10
P30.17	AO2 measured voltage 1	0.500V~4.000V	Factory-corrected	◇	AC11
P30.18	AO2 targeted voltage 2	6.000V~9.999V	Factory-corrected	◇	AC12
P30.19	AO2 measured voltage 2	6.000V~9.999V	Factory-corrected	◇	AC13

Chapter 7 Faults and Solutions

7-1. Fault informations and solutions

PT300 provides a total of 24 pieces of fault information and protective functions. Once fault occurs, the inverter implements protective functions, and stops the output, the inverter's fault relay actions, and display the fault code on operation panel. Before contacting manufacturer for technical support, you can first determine the fault type, analyze the causes and find the solutions. If the troubleshooting belongs to the types of the following diagram, contact the agent or manufacturer for help.

E.Inv is the overvoltage or overcurrent signal of these 21 warning information items. In most situations, E.Inv is caused by hardware overvoltage.

Sequence	Fault code	Fault type	Possible causes	Solutions
1	E. oCX X (1. 2. 3)	Inverter unit U protection Inverter unit V protection Inverter unit W protection	1、 The output circuit short-circuited 2、 The connecting cable of the motor is too long . 3、 The module overheats 4、 The internal connections Becoming loose. 5、 The main control board abnormal 6、 Drive board abnormal 7、 The inverter module abnormal	1、 Eliminate external faults 2、 Install a reactor or an output filter 3、 Check the air filter and cooling fan 4、 Connect all cables properly 5、 Contact manufacturer for technical support 6、 Contact manufacturer for technical support 7、 Contact manufacturer for technical support
2	E.oC1	Overcurrent during acceleration	1、 The output circuit grounded or short-circuited 2、 Control mode is VC, and the motor auto-turning is not performed 3、 The acceleration time is too short 4、 Manual torque boost and V/F curve is not appropriate 5、 The voltage is too low 6、 The startup operation is performed on the rotating motor 7、 A sudden load is added during acceleration 8、 The inverter model is of too small power class	1、 Eliminate external faults 2、 Perform the motor auto-turning 3、 Increase the acceleration time 4、 Adjust the manual torque boost or V/F curve 5、 Adjust the voltage to normal range 6、 Select rotational speed tracking restart or start the motor after it stops 7、 Remove the added load 8、 Select an inverter of higher power class
3	E.oC2	Overcurrent during deceleration	1、 The output circuit grounded or short-circuited 2、 Control mode is VC, and the motor auto-turning is not performed 3、 The deceleration time is too short 4、 The voltage is too low 5、 A sudden load is added during deceleration 6、 The braking unit and	1、 Eliminate external faults 2、 Perform the motor auto-turning 3、 Increase the deceleration time 4、 Adjust the voltage to normal range 5、 Remove the added load 6、 Install the braking unit and braking resistor

Chapter 7 Faults and Solutions

Sequence	Fault code	Fault type	Possible causes	Solutions
			braking resistor are not installed	
4	E.oC3	Overcurrent at constant speed	<ol style="list-style-type: none"> 1. The output circuit grounded or short-circuited 2. Control mode is SVC, and the motor auto-turning is not performed 3. The voltage is too low 4. A sudden load is added during deceleration 5. The inverter model is of too small power class 	<ol style="list-style-type: none"> 1. Eliminate external faults 2. Perform the motor auto-turning 3. Adjust the voltage to normal range 4. Remove the added load 5. Select an inverter of higher power class
5	E.oU1	Overvoltage during acceleration	<ol style="list-style-type: none"> 1. The input voltage is too high 2. An external force drives the motor during acceleration 3. The acceleration time is too short 4. The braking unit and braking resistor are not installed 	<ol style="list-style-type: none"> 1. Adjust the voltage to normal range 2. Cancel the external force or install a braking resistor 3. Increase the acceleration time 4. Install the braking unit and braking resistor
6	E.oU2	Overvoltage during deceleration	<ol style="list-style-type: none"> 1. The input voltage is too high 2. An external force drives the motor during deceleration 3. The deceleration time is too short 4. The braking unit and braking resistor are not installed 	<ol style="list-style-type: none"> 1. Adjust the voltage to normal range 2. Cancel the external force or install a braking resistor 3. Increase the deceleration time 4. Install the braking unit and braking resistor
7	E.oU3	Overvoltage at constant speed	<ol style="list-style-type: none"> 1. The input voltage is too high 2. An external force drives the motor during deceleration 	<ol style="list-style-type: none"> 1. Adjust the voltage to normal range 2. Cancel the external force or install a braking resistor
8	E.Br	Buffer resistor overload fault	<ol style="list-style-type: none"> 1. The input voltage is not within the allowable range 	<ol style="list-style-type: none"> 1. The input voltage is not within the allowable range
9	E.LU	Undervoltage	<ol style="list-style-type: none"> 1. Instantaneous power failure 2. The input voltage is not within the allowable range 3. The DC bus voltage is abnormal 4. The rectifier bridge and buffer resistor are abnormal 5. The drive board is abnormal 6. The control board is abnormal 	<ol style="list-style-type: none"> 1. Reset the fault 2. Adjust the voltage to normal range 3. Contact manufacturer for technical support 4. Contact manufacturer for technical support 5. Contact manufacturer for technical support 6. Contact manufacturer for technical support
10	E.oL1	inverter overload	<ol style="list-style-type: none"> 1. The load is too heavy or locked-rotor occurs on the motor 	<ol style="list-style-type: none"> 1. Reduce the load and check the motor and mechanical condition

Sequence	Fault code	Fault type	Possible causes	Solutions
			2、 The inverter model is of too small power class	2、 Select an inverter of higher power class
11	E.oL2	Motor overload	1、 P09.01 is set improperly 2、 The load is too heavy or locked-rotor occurs on the motor 3、 The inverter model is of too small power class	1、 Set P09.01 properly 2、 Reduce the load and check the motor and mechanical condition 3、 Select an inverter of higher power class
12	E.PHI	Input phase loss	1、 The 3-phase power input is abnormal 2、 The drive board is abnormal 3、 The lightning board is abnormal 4、 The control board is abnormal	1、 Eliminate external faults 2、 Contact manufacturer for technical support 3、 Contact manufacturer for technical support 4、 Contact manufacturer for technical support
13	E.PHo	Output phase loss	1、 The cable connecting the inverter and motor is faulty 2、 The inverter's 3-phase outputs are unbalanced during the motor is running 3、 The drive board is abnormal 4、 The module is abnormal	1、 Eliminate external faults 2、 Check whether the motor three-phase winding is normal 3、 Contact manufacturer for technical support 4、 Contact manufacturer for technical support
14	E.oH1	Module overheat	1、 The ambient temperature is too high 2、 The air filter is blocked 3、 The fan is damaged 4、 The thermally sensitive resistor of the module is damaged 5、 The inverter module is damaged	1、 Lower the ambient temperature 2、 Clean the air filter 3、 Replace the damaged fan 4、 Replace the damaged thermally sensitive resistor 5、 Replace the inverter module
15	E.SET	External equipment fault	1、 External fault signal is input via DI 2、 External fault signal is input via virtual I/O	1、 Reset the operation 2、 Reset the operation
16	E.CE	Communication fault	1、 The host computer is in abnormal state 2、 The communication cable is abnormal 3、 P00.28 set is improperly 4、 The communication parameters in P14 are set improperly	1、 Check the cabling of the host computer 2、 Check the communication cabling 3、 Set the extension card parameters correctly 4、 Set the communication parameters properly
17	E.CoN	Contact fault	1、 The drive board and power supply are abnormal 2、 The contactor is abnormal	1、 The drive board and power supply are abnormal 2、 The contactor is abnormal
18	E.oCC	Current detection fault	1.The connector of the control board is not connect well 2.Auxiliary power fault 3.The HALL device fault 4.The amplify circuit is	1. Check the connector 2. Contact manufacturer for technical support 3. Contact manufacturer for technical support

Chapter 7 Faults and Solutions

Sequence	Fault code	Fault type	Possible causes	Solutions
			abnormal	4. Contact manufacturer for technical support
19	E.TE	Motor auto-turning fault	<ol style="list-style-type: none"> 1.The capacity of motor and inverter are not match 2.The motor' s parametes are not set properly 3.The parameters between auto-turning and standard are of big deviation 4. Auto-turning time out 	<ol style="list-style-type: none"> 1. Replace the inverter model 2.Set the parameters according to the motor nameplate 3.Auto-turning with the motor no-load 4. Check the motor cabling and parameter setting
20	E.Enco	Encoder fault	<ol style="list-style-type: none"> 1、 The encoder type is incorrect 2、 The cable connection of encoder is incorrect 3、 The encoder is damaged 4、 PG card abnormal 	<ol style="list-style-type: none"> 1、 Set the encoder type correctly based on actual situation 2、 Eliminate external fault 3、 Replace the damaged encoder 4、 Replace the PG card
21	E.EEP	EEPROM R/W fault	1.EEPROM chip is damaged	1、 Replace the control board
22	E.INv	inverter hardware fault	<ol style="list-style-type: none"> 1、 Overvoltage exists 2、 Overcurrent exists 	<ol style="list-style-type: none"> 1、 Handle based on overvoltage 2、 Handle based on Overcurrent
23	E.STG	Short circuit to ground	1、 The motor is short circuited to the ground	1、 Replace the cable or motor
26	E.TIo	Accumulative running time reached fault	1、 Accumulative running time reaches the setting value	1、 Clear the record through parameter initialization function
27	E.USE1	User-defined fault 1	<ol style="list-style-type: none"> 1、 The user-defined fault 1 signal is input via DI 2、 The user-defined fault 1 signal is input via virtual IO 	<ol style="list-style-type: none"> 1、 Reset operation 2、 Reset operation
28	E.USE2	User-defined fault 2	<ol style="list-style-type: none"> 1 The user-defined fault 2 signal is input via DI 2、 The user-defined fault 1 signal is input via virtual IO 	<ol style="list-style-type: none"> 1、 Reset operation 2、 Reset operation
29	E.PUTO	Accumulative power-on time reached fault	1、 Accumulative power-on time reaches the setting value	1、 Clear the record through parameter initialization function
30	E.LOAD	Load lost fault	1、 The inverter' s running current is lower than P10.64	1、 Make sure whether the load is connected or parameters of P10.64、 P10.65 are correct
31	E.PId	PID feedback lost during Running	1、 PID is lower than the P11.26 setting value	1、 Check PID feedback signal or set P11.26 to a proper value
32	E.tSF	Hydraulic probe damaged	1. The detected water level control analog signal is greater than the P15.18 hydraulic probe damage point.	1. Check if the water level control analog signal is greater than the P15.18 hydraulic probe damage

Sequence	Fault code	Fault type	Possible causes	Solutions
				point.
33	A-LL	Water shortage warning	1. The feedback value is less than the water shortage fault setting value	1. Check that the feedback value is less than the water shortage fault setting.
34	A-tF	Full water warning	1. The detected water level control analog signal is less than the P15.15 water level threshold.	1. Check that the water level control analog signal is less than the P15.15 water level threshold.
40	E.CBC	Pulse by pulse current limit fault	1. The load is too heavy or locked-rotor occurs on the motor 2. The inverter is of too small power class	1. Reduce the load and check the motor and mechanical condition 2. Select an inverter of higher power class
41	E.SrUN	Motor switchover fault during running	1. Change the selection of the motor via terminal during running of the inverter	1. Perform motor switchover after inverter stops.
42	E.SSD	Too large speed deviation fault	1. The encoder parameters are set improperly 2. The motor auto-turning is not performed 3. P10.69 and P10.60 are set incorrectly	1. Set the encoder parameters properly 2. Perform the motor auto-turning 3. Set P10.69 and P10.60 correctly based on actual situation
43	E.oS	Motor over-speed fault	1. The encoder parameters are set incorrectly 2. The motor auto-turning is not performed 3. P10.69 and P10.60 are set incorrectly	1. Set the encoder parameters properly 2. Perform the motor auto-turning. 3. Set P10.69 and P10.60 correctly based on actual situation
44	E.oH2	Motor overheat fault	1. The cabling of temperature sensor becomes loose 2. The temperature of motor is too high	1. Check the temperature sensor cabling and eliminate the cabling fault 2. Lower the carrier frequency or adopt other heat radiation measures.
45	E.INIT	Initial position fault	1. The motor parameters are of large deviation of the actual .	1. Check that the motor parameters are set correctly and whether the setting of rated motor current is too small
46	A-HP	High water pressure fault	1. The feedback pressure value is higher than the high pressure alarm value setting (P15.04).	1. Check the pressure sensor's feedback value, it is too large
47	A-LP	Low water pressure fault	1. The feedback pressure value is lower than the high pressure alarm value setting (P15.05).	1. Check the pressure sensor's feedback value, it is too small

7-2. Common Faults and Solutions

You may come across the following faults during the use of the inverter, refer to the following table for simple fault analysis:

Table 8-1 Common faults and Solutions:

1	There is no display at power-on	<p>There is no power supply to inverter or the power input to inverter is too low; The power supply of the drive board of AC drive is faulty; The rectifier bridge is damaged; The buffer-resistor of the inverter is damaged; The control board and the operation panel are faulty; The cabling between control board and drive board and operation panel breaks ;</p>	<p>Check the input power supply; Check the DC bus voltage; Re-connect the 8-core or 28-core cables. Contact manufacturer for technical support;</p>
2	PT300 is displayed at power-on	<p>The cable between control board and drive board is in poor contact; Related components of the control board are damaged; Re-connect the 8-core or 28-core cable ; The motor or the motor cable is short-circuited to ground; Contact manufacturer for technical support; The HALL device is faulty ; The power input to the inverter is too low;</p>	
3	"E.STG" is displayed at power-on	<p>The motor or the motor cable is short-circuited to ground; The inverter is damaged;</p>	<p>Measure the insulation of the motor and the motor output cable with a megger ; Contact manufacturer for technical support;</p>
4	The inverter display is normal .But PT300 is displayed after running and stops immediately	<p>The cooling fan is damaged or locked-rotor occurs; The external control terminal cable is short circuited;</p>	<p>Replace the cooling fan ; Eliminate the external short circuited fault ;</p>
5	E.oH1(module overheat) fault is reported frequency	<p>The setting of carrier frequency is too high. Lower the setting of the carrier frequency(P01.15) . The cooling fan is damaged or locked-rotor occurs. Replace the cooling fan and clean the air filter . Components inside inverter are damaged(Thermal coupler or others) The motor and the motor cabling; The setting parameters of the inverter</p>	

		is faulty(The motor parameters) :	
6	The motor does not rotate after the inverter runs	The motor and the motor cabling; The setting parameters of the inverter is faulty(The motor parameters) ; The cable between control board and drive board is in poor contact; The control board is faulty;	Ensure the cable between the inverter and motor is normal; Replace the motor and clear the mechanical faults ; Check the reset motor parameters ;
7	DI terminals are invalid	The parameters are set incorrectly ; External signals is incorrect; The jump bar between OP and +24V becomes loose; The control board is faulty;	Check and reset the corresponding parameters of P05 group; Re-connect the external signal cable; Ensure the jump bar between OP and +24V; Contact manufacturer for technical support;
8	The motor speed is always low in CLVC control mode	The encoder is faulty; The encoder cable is connected incorrectly or in poor contact; The PG card is faulty; The control board is faulty;	Replace the encoder and ensure the cable connect properly; Replace the PG card; Contact manufacturer for technical support;
9	Replace the encoder and reconfirm the wiring; Replace PG card; Seeking services;	The motor parameters are set improperly; The acceleration /deceleration time is improper; The load fluctuates;	Reset the motor parameters or perform the motor auto-turning; Set the proper acceleration /deceleration time; Contact manufacturer for technical support;
G	450~560	The soft startup contactor is not picked up	Check whether the contactor cable is loose; Check whether the contactor is faulty; Check whether 24V power supply of the contactor is faulty; Contact manufacturer for technical support;
P	500~630	Related components of control board are damaged;	Replace the control board

Chapter 8 Appendix

RS485 Extension card 300RS485

Summarize

300RS485 extension card is specially developed for supporting isolated RS485 communication function for PT300 series inverter. The electrical parameters comply with international standards. The user can choose the AC Drive according to require, it can realize the functions such as inverter remote operation and parameter setting.

Items	Specification	Representation
Communication	RS485 communication interface	Support Modbus-RTU protocol

Control terminal illustration:

Type	Terminal symbols	Terminal name	Function illustration
RS485 communication	485+/485-	Communication interface terminal	Isolated input terminal of RS485
	CGND	Power ground of RS485 communication	Isolated Power

RS485 Communication Protocol

1. Introduction

PT300 series inverter, which support RS232/RS485 communication interface, adopt international standard MODBUS communication protocol of master-slave communication. The user can realize the central-control via PC/PLC and master-computer to satisfy the special application requirement (Set the inverter's command source and running frequency; Modify the relative function parameters; Monitoring the inverter's work status and fault information).

2. Specifications

I、Protocol content

The serial communication protocol defines information content and format of the serial Communication transmission. Including: host polling (or broadcast) format; The host machine encoding method, the content includes: the function code of the required action, data transmission and error checking, etc. The response of the slave machine is also using the same structure, content including: action confirmation, data feedback and error checking, etc. If there is an error of the slave in receiving information, or cannot achieve the requirements of the host, it will organize a fault feedback information in response to the host.

II、Application mode

The inverter access with a “single master –multi slave” PC/PLC control network with RS232/RS485 bus.

III、Bus structure

(1) Interface mode: RS232(JP8 2-3 short circuit)/RS485(JP8 1-2 short-connected) hardware interface.

(2) Transmission mode:

Asynchronous serial, half-duplex transmission mode. At the same time, the master and slave can only transmit data while the other can only receive data. In the series asynchronous communication, In the form of packets sent frame by frame.

Asynchronous serial, half-duplex transmission mode. Only one of the master and slave can transmit data at the same time while the other can only receive data.

(3) Topology:

Single-master multi-slave system. Slave address range is 1 to 247, 0 is broadcast communication address.

Network slave address must be unique. As shown below:

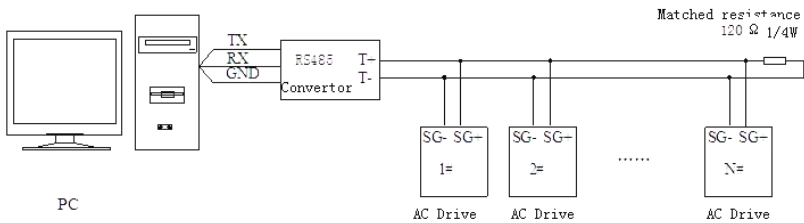

IV、Protocol Description

PT300 series inverter communication protocol is an asynchronous serial master-slave MODBUS communication protocol, Only one network device (Master) can establish protocol (called " inquiry / command"). Other devices (slave) can only respond to the Master by providing data "inquiry / command", Or make the appropriate action based on the Master of "inquiry / command".

The Master refers personal computer (PC), industrial control equipment or a programmable logic controller (PLC) etc. and the slave refers PT300 inverter. Master can communicate a Slave individually, And also can for all the lower Slave broadcast information. For the Master individual access "inquiry / command", the Slave must return a message (called a response), the broadcast information provided by Master, The Slave needs not feedback a response to the Master.

V、Communication data structure

PT300 series inverter MODBUS protocol communication data format is RTU (remote terminal unit mode).

Chapter 8 Appendix

(1) In RTU mode, each byte format is as follows:

In RTU mode, a message is sent, at least need 3.5 character times interval to begin. In the network baud rate diverse character time, This is most easily achieved (as shown in the T1-T2-T3-T4). The first field then transmitted is the device address. Characters transmitted is hexadecimal 0 ... 9, A ... F. Networked devices monitor the network bus, including the pause time interval. When the first field (the address field) is received, each device decodes it to determine whether or not sent to their own. After the last transmitted character, at least a 3.5 character times interval marks the message END. A new message can begin after this interval. The entire message frame must be transmitted as a continuous flow of transport. If more than 1.5 characters times interval before the frame finished, The receiving device will refresh the incomplete message and assumes that the next byte is the address field of a new message. Likewise, if a new message in less than 3.5 character times following a previous message began, The receiving device will consider it a continuation of the previous message. This will result in an error, because it is impossible in the value of the final CRC field is correct.

RTU frame format:

START	T1-T2-T3-T4(3.5 bytes transfer time)
ADDR	Communication Address: 0~247(Decimal) (0 is Broadcast address)
Functional domain CMD	03H: Read the Slave parameters; 06H: Write the Slave parameters
Data Domain DATA(N-1) ... DATA(0)	2*N bytes of data, which is part of the main content of the communication, but also is the data exchange core of communication.
CRC CHK low bit	Detection value: CRC Checksum value(16BIT)
CRC CHK high bit	
Frame END	T1-T2-T3-T4(3.5 bytes transfer time)

CMD(Command) and DATA(Data description) CMDcode: 03H, Read N characters(Word) (Max to 16 characters can be read) For example: the Slave address 01 inverter's starting address 0107, Continuous read 2 consecutive values of the Master command information RTU Master command information.

START	T1-T2-T3-T4
ADDR	01H
CMD	03H
The starting address high byte	01H
The starting address low byte	07H
High data byte	00H
Low data byte	02H
CRC CHK Low byte	Pending its calculated CRC CHK value
CRC CHK High byte	
END	T1-T2-T3-T4

RTU Slave Response Information.

START	T1-T2-T3-T4
ADDR	01H
CMD	03H
The number of bytes	04H
Data address 0007H High byte	13H
Data address 0007H Low byte	88H
Data address 0008H High byte	13H
Data address 0008H Low byte	88H
CRC CHK Low byte	Pending its calculated CRC CHK value
CRC CHK High byte	
END	T1-T2-T3-T4

Check mode——CRC Check mode: CRC(Cyclical Redundancy Check)

Using RTU frame format, the message contains a based CRC method error domain detection. CRC field checks the contents of the entire message. CRC domain is two bytes, containing a 16-bit binary value. After it is calculated by the transmission equipment is added to the message. The receiving device recalculates the received message CRC, And compared with the value of the received CRC domain, If the two CRC values are not equal, then the transmission error.

CRC is first stored in 0xFFFF, Then the message calls a procedure in consecutive 8-bit bytes with the value of the current register for processing. Only each character 8Bit data is valid for CRC, Start and stop bits, and parity verify bit are invalid. CRC generation process, each of the eight characters are separate and register contents mutually exclusive or(XOR) , Results to the lowest significant bit move, the highest significant bit to 0 padding. LSB is extracted detected, If the LSB is 1, the register's individually and preset value XOR, If the LSB is 0, not process. The whole process is repeated 8 times. After the last bit (8th bit) is completed, The next 8 bytes, will separate and the register's current value XOR again. The final value of the register is CRC value of the message in all of the bytes after the execution.

CRC is added to the message, the low byte first, followed by the high byte. CRC simple function as follows:

```

unsigned int crc_chk_value(unsigned char *data_value, unsigned char length)
{
    unsigned int crc_value=0xFFFF;
    int i;
    while(length--)
    {
        crc_value^=*data_value++;
    }
    for(i=0;i<8;i++)

```

Chapter 8 Appendix

```

{
if(crc_value&0x0001)
{
crc_value=(crc_value>>1)
^0xa001;
}
else
{
crc_value=crc_value>>1;
}
}
}
return(crc_value) ;
}

```

The communication parameters address define

This part is the content of the communication, for controlling the operation of the inverter, inverter status and related parameters setting. Read and write function code parameter (some function code can not be changed, for factory use only):

Function code parameter address label rules:

Function code group number and label number for the parameter address rules:

High byte: 70(P00) 、 F0~FF(P01-P16) 、 A0~AC(P18-P30)

Low byte: 00~FF

For example: P02.10, Address expressed as F10A (Hex);

P18.01, Address expressed as A001 (Hex);

Note: P00 Group: parameter read-only, can not change the parameters;

P16 Group: neither read parameters, nor alter parameters; Some parameters when the inverter is running, can not be changed; Some parameters regardless of what state drive, can not be changed; Change the function code parameters, pay attention to the parameter range, unit and related instructions.

In addition, since the EEPROM memory frequently will reduce the life of the EEPROM, Therefore, some function codes in communication mode, no memory, Only need to change in the value of RAM on it. To achieve this function, Only need to this function code address (P01-P16) high F becomes 0 can be achieved, and Function code address (P18-P30) high bit A change into 4 can be achieved. In the following table:

Function code group No.	Function code communication access address(EEPROM)	Communication modification function code address (RAM)
P00	0x7000-0x70FF	
P01-P16	0xF000-0xFFFF	0x0000-0x0FFF
P18-P30	0xA000-0xACFF	0x4000-0x4CFF

The corresponding function code shown by the following address:

High byte: 00~0F(P01-P16) 、 40~4F(P18-P30)

Low byte: 00~FF

Such as: function code P02.10 is not stored in EEPROM, Address expressed as 010AH; The address represents only for writing RAM, can not for reading action, Invalid address when read.

Run/Stop parameter part:

Parameter Address	Parameter Description
1000H	Communication setting value(-10000~10000) Decimal
1001H	Running Frequency
1002H	DC-Bus Voltage
1003H	Output Voltage
1004H	Output Current
1005H	Output Power
1006H	Output Torque
1007H	Running Speed
1008H	DI Input Flag
1009H	DO Output Flag
100AH	AI1 Voltage
100BH	AI2 Voltage
100CH	AI3 Voltage
100DH	Count value input
100EH	Length value input
100FH	Load speed
1010H	PID setting value
1011H	PID Feedback value
1012H	PLC Procedure
1013H	Input pulse frequency, Unit : 0.01kHz
1014H	The speed of feedback, Unit : 0.1Hz
1015H	Remain running time
1016H	AI1 voltage before correction
1017H	AI2 voltage before correction
1018H	AI3 voltage before correction
1019H	Linear speed
101AH	Current power-on time
101BH	Current running time
101CH	Input pulse frequency, Unit 1Hz
101DH	Communication setting value
101EH	The actual speed of feedback
101FH	Main Frequency X display
1020H	Auxiliary Frequency Y display

Chapter 8 Appendix

The communication setting value is the percentage of the relative value. 10000 corresponds to 100.00%, -10000 corresponds to -100.00%. To the frequency dimensional data, this percentage is relative to the percentage of maximum frequency(P01.10). To the rotating torque dimensional data, this percentage is P03.10, P20.48, P21.48, P22.48 which correspond to the 1st, 2nd, 3rd, 4th motor.(Digital setting of torque upper limit)

Control command input to inverter: (Write only) .

Command word address	Command function
2000H	0001H: Forward run
	0002H: Reverse run
	0003H: Forward JOG
	0004H: Reverse JOG
	0005H: Coast to stop
	0006H: Deceleration to stop
	0007H: Fault reset

inverter R/W state: (Read only) .

Status word address	Status word function
3000H	0001H: In the operation of the forward run
	0002H: In the operation of the Reverse run
	0003H: inverter stops

Password verifying of parameter lock: (If feedback 8888H, means the password verifying passed) .

Password Address	The content of the input password
1F00	*****

The communication parameter initialize address is 1F0H, the data content are defined as follows:

Communication address for parameter initialization	Command function
1F01H	1: Recovery parameters to factory setting
	2: Storage record information
	4: Recovery the user backup parameters
	5: Backup the current user parameters

Digital output terminal control: (Write only) .

The Command Address:	The Command Content:
2001H	BIT0: D01 output control BIT1: D02 output control BIT2: RELAY1 output control BIT3: RELAY2 output control BIT4: SPR output control BIT5: VDO1 BIT6: VDO2 BIT7: VDO3 BIT8: VDO4 BIT9: VDO5

Analog output AO1 control: (Write only) .

The Command Address:	The Command Content:
2002H	0-7FFF correspond to 0-100%

Analog output A02 control: (Write only).

The Command Address:	The Command Content:
2003H	0-7FFF correspond to 0-100%

Pulse output SPP control: (Write only) .

The Command Address:	The Command Content:
2004H	0-7FFF correspond to 0-100%

inverter fault description:

Inverter fault address	Fault code	inverter fault information
8000H		0000: No fault
		0001: Reserved
	E.oC1	0002: Overcurrent during acceleration(oC1)
	E.oC2	0003: Overcurrent during deceleration(oC2)
	E.oC3	0004: Overcurrent at constant speed(oC3)
	E.oU1	0005: Overvoltage during acceleration(oU1)
	E.oU2	0006: Overvoltage during deceleration(oU2)
	E.oU3	0007: Overvoltage at constant speed(oU3)
	E.Br	0008: Buffer resistor overload fault
	E.LU	0009: DC-bus undervoltage fault(LU)

8000H	E.oL2	000A: inverter overload(oL2)
	E.OI1	000B: Motor overload(oL1)
	E.PHI	000C: Input power phase loss(PHI)
	E.PHo	000D: Output power phase loss(PHo)
	E.oH1	000E: Module overheat fault(oH1)
	E.SET	000F: External fault(EF)
	E.CE	0010: Communication fault (CE)
	E.CoN	0011: Contactor fault
	E.oCC	0012: Current detection fault(oCC)
	E.TE	0013: Motor auto-turning fault(TE)
	E.Enco	0014: Encoder/PG card fault
	E.EEP	0015: EEPROM operation fault(EEP)
	E.INT	0016: inverter hardware fault
	E.STG	0017: Motor short-circuited to ground fault
	E.BL	0018: Reserved
	E.oH2	0019: Reserved
	E.TIo	001A: Accumulative running time reached
	E.USE1	001B: User-defined fault 1
	E.USE2	001C: User-defined fault 2
	E.PUTo	001D: Accumulative power-on time reached
	E.LOAD	001E: No load fault
	E.PId	001F: PID feedback signal lost during running(PIDE)
	E.CBC	0028: Fast current limit time out fault
	E.SrUN	0029: Motor disconnected during running fault
	E.SDD	002A: Too large speed deviation fault
	E.oS	002B: Motor overspeed fault
	E.OH2	002D: Motor overheat fault
	E.INIT	005A: Encoder pluses set incorrectly
	E.FDB	005B: Encoder is not connected
		005C: Initial position fault
		005D: Speed feedback fault

Description data of Communication fault information(Fault code) :

Communication fault address	Communication fault function description:
8001H	0000: No fault 0001: Password fault 0002: Command code fault 0003: CRC correction fault 0004: Invalid address 0005: Invalid parameter 0006: Parameter modified invalid 0007: System locked 0008: EEPROM is in operation

Chapter 9 Quality Assurance

The product quality assurance in accordance with the following provisions:

- 1、 The specific content of the quality assurance belongs to Manufacturer's responsibility:
 - 1-1、 When used in the domestic(Calculate date is the products shipped day)
 - ※ Refund, replacement, repair within one month after shipped.
 - ※ Replacement, repair within 3 months after shipped.
 - ※ Repair within 12 months after shipped.
 - 1-2、 When used in overseas, Repair in the local distributor or manufacturer within 6 months after shipped.
- 2、 No matter when, where use of the products, all paid service for all time.
- 3、 The company in the sales, production, agents can provide service for this product, its conditions of service as follows:
 - 3-1、 The unit is located in a "3-step" Inspection Service (including troubleshooting).
 - 3-2、 Service responsibility standards according to the contract of dealer and manufacturer.
 - 3-3、 Can be paid to each manufacturer's distributor, requests for service (whether within the warranty or not).
- 4、 This product has the quality problem or accident of product liability, up to 1-1 or 1-2 only assume responsibility for those two terms, if the user needs more assurance liability, property insurance coverage in advance of your own insurance company.
- 5、 Warranty period is one year when shipped.
- 6、 If it is the following causes of failure, even during the warranty period, also is paid to repair:
 - 6-1、 Improper operation (depending on the user manual), or unauthorized repair or alteration caused problems.
 - 6-2、 Caused problems by use the inverter beyond the standard specification.
 - 6-3、 Damaged caused by improper handling after the purchase.
 - 6-4、 Devices aging or failure caused by adverse environment.
 - 6-5、 Caused by earthquake, fire, wind and flood damage, lightning, abnormal voltage or other natural disasters.
 - 6-6、 Damage during transport (Note: Transport item is specified by the customer, the company help to handle transfer of goods).
 - 6-7、 When manufacturer label brands, trademarks, serial number, nameplate damaged or illegible.
 - 6-8、 Failing to pay the agreed purchase payments.
 - 6-9、 For installation, wiring, operation, maintenance or other use of objective reality can not describe to the manufacturer.
- 7、 For refund, replacement, repair service, customers must return the goods to manufacturer, after confirmation accountability before be returned or repaired.